

3D TUMBLER EM-7

INSTRUCTIONS

Serial Number: A001-



YASUI & CO.

3-7-4 Ikejiri, Setagaya-ku, Tokyo 154-0001, Japan

Keep this manual for your future reference.

- The manufacturer is completely exempt from any damage which occurred by having used this product.

Purchaser must use this product following this provisional instruction manual supplied with the product, caution label on the product, without any mistake on operation, in a poor environment, without ignoring advice, warning, caution of risk aversion mentioned on the labels and provisional instruction manual, without using any options and consumption which is not officially allowed by manufacturer, without spiteful modification without permission which causes damages to product, operator, architectures and others.

- Purchaser must keep safety instructions mentioned in the provisional manual as well as the ordinances in each region.

- The manufacturer is completely exempt from any production or profit (or any other) sustains directly nor indirectly by using this product.

- The manufacturer is completely exempt from any damages while operation with operation mistake and nor delayed services by manufacturer.

- Polishing results by the machine or by this manual are not compensated by the manufacturer.

- No part of this document may be copied or in any way reproduced without the expressed written consent of the manufacturer.

CONTENTS

1. SAFETY INSTRUCTION.....	5
2. INTRODUCTION	7
2-1. SPECIFICATION LABEL	7
2-2. SPECIFICATION in detail	8
2-2-1. DEMENSION	8
2-2-2. POWER SUPPLY	9
2-2-3. Parameter setting	10
2-2-4. STATUS of progress	11
2-2-5. STATUS of progress	12
2-2-6. WORKING CONDITIONS	12
3. NOMENCLATURE.....	13
3-1. OUTSIDE VIEW	13
3-2. BODY	14
3-3. OPERATION PANEL	15
3-4. CONTROL CABINET	17
4. INSTALLATION.....	18
4-1. ACCESSORIES.....	18
4-2. INSTALLATION	18
4-2-1. WORKING CONDITIONS	18
4-2-2. WORKING CONDITIONS	19
4-2-3. SIGNAL TOWER.....	20
4-2-4. POWER CABLE	21
4-3. TRANSPORTATION	21
5. OPERATION.....	22
5-1. POLISHING.....	22
5-2. PARAMETER SETTING	26
5-2-1. PARAMETERS.....	26
5-2-2. OPERATION	29
6. ADVANCED OPERATION	31
6-1. PARAMETER SETTINGS.....	31
6-1-1. TPT (Total Process Time)	31
6-1-2. RPT (Reverse Process Time)	33
6-1-3. RS (Rotation Speed setting)	34
6-1-4. PP (Process Pattern).....	36
6-1-5. AT (Acceleration Time)	38
6-1-6. ST (Slowdown Time)	39
6-1-7. CCWS (Counter Clockwise Setting)	41
6-1-8. BS (Buzzer Setting).....	43

6-1-9. Memory (Memory number Setting)	44
6-2. ADDITIONAL INFORMATION.....	47
7. ERROR MESSAGES	49
8. MAINTENANCE	53
9. CONSUMABLES	55
10. WORDS AND TERMS	56
11. DIAGRAM.....	58

1. SAFETY INSTRUCTION

Describing very important cautions and handling of the product at this chapter.

【  WARNING】 describes the thing which there is possibility of "the accident to be tied to the death or a serious wound" by incorrect handling.

【  CAUTION】 describes the thing which there is possibility of "the accident to be tied to a serious injury or product defective" by incorrect handling.



WARNING

【Warning in general】

- 1) Power supply must be only 3 phase, 230VAC for this product.
- 2) Do not move this product when power supplied, maintenance and wiring is not allowed as well.
Turn off power and wait for more than 1 minute before working on it.
- 3) Transportation, installation, wiring, operation and maintenance must be made by a qualified specialist.
- 4) Do not turn ON when panel board is opened.
Never touch electric terminal to prevent an electric shock.
- 5) Double check ground cable is surely connected to proper ground terminal.
- 6) Do not bend, pull or bind electric cables.
Replace wound cables, plug and socket.
- 7) Do not touch plug and socket with wet hands.
The space around this product must be kept dried.
Pay attention of control panel from water hit.

【Operation】

- 1) Do not put too much workpieces and polishing media into container.
- 2) Do not operate without workpieces and polishing media in container
- 3) Turn off the machine and remove electric plug from socket when you have thunderbolt outside
- 4) Turn off earth leakage breaker at blackout.

【Others】

- 1) Do not try to repair or disassemble this product by yourself.
Call Yasui if you need our help.



CAUTION

【Caution in general】

- 1) Do not use this product for other purpose.
- 2) Do not put anything in front of exhaust port and inside.
Machine can be defective by lack of cooling down.
Do not try to touch exhaust port or air inlet.
- 3) Do not put anything which disturbs operator around this product.
Do not put anything flammable around this product.
- 4) Pay attention when moving this product.
- 5) Unplug cable when no operation, Turn off earth leakage breaker beforehand.
- 6) Do not try to modify any part of this product, hardware nor software.
- 7) Particular care should be taken so that any other person does not touch this product.
- 8) Put acrylic pot in the chamber very carefully not to give any damage on chamber and pot.

【Operation】

- 1) Do not touch container when polishing.
Do not try unnecessary operation on panel.
* Do not give irregular operations like long press on several buttons to prevent malfunction.
- 2) Do not put anything nor hands in container when polishing.
- 3) Stop operation immediately at emergency.
- 4) Water gets hot by long, continuous operation.

【Others】

- 1) Stop operation if you find defectives on workpieces.
- 2) Do not scatter polishing media on and inside of machine body.
Wear gloves at handling polishing pins to prevent injury.
- 3) Maintain polishing media clean always to get stable polishing results.
- 4) Polishing media and other accessories must be from Yasui.
- 5) Do not use any liquid except for water.
- 6) You need to be careful not to drop container as it is very heavy with workpieces, polishing media, water and compound.
- 7) Keep anything affected by strong magnetic field away from this product.
- 8) Maintain this product and accessories clean always for continuous stable polishing result.

2. INTRODUCTION

This product is for polishing and deburring on workpieces made of non-magnetic metal parts and plastic products with very fine polishing media.

It generates very powerful magnetic field which rotates and forces polishing media to hit a big volume of workpieces.

2-1. SPECIFICATION LABEL

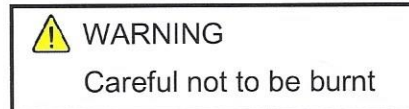
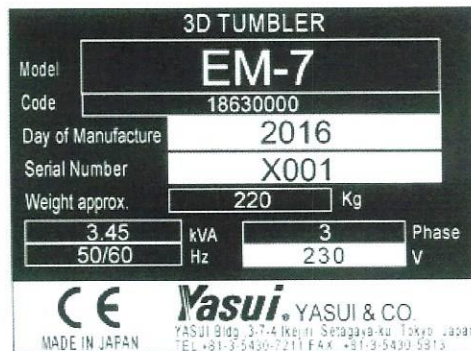

1) The principal specifications label of this machine is affixed on control cabinet.
Apply power specified voltage printed on the label. Should any voltage exceed beyond the specified voltage, the manufacturer is not responsible to guarantee performance of EM-7.

2) When ordering spare parts, specify the production serial number that is printed on that label.
Take note of information on this label.

** Structures and equipments can be slightly differed on each body depending on production lot.
The basic performance and operation will not be changed.

2-2. SPECIFICATION in detail

2-2-1. DEMENSION

Following dimensions of body and container of EM-7.

3D TUMBLER

EM-7

Weight approx. 252kg

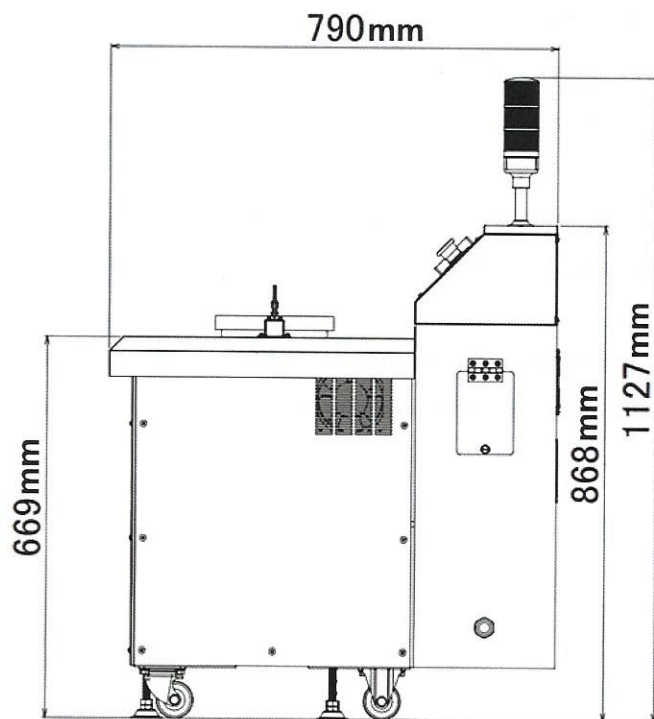
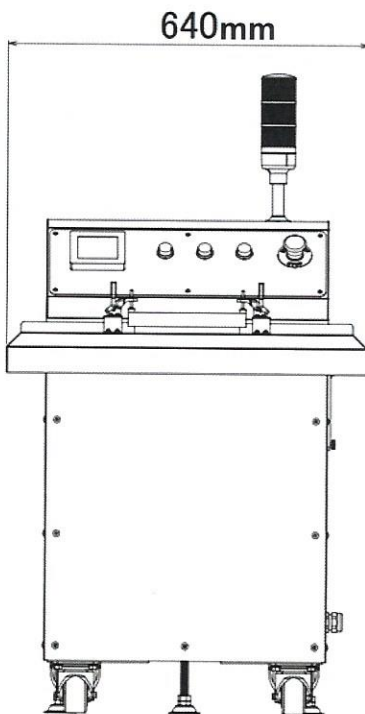
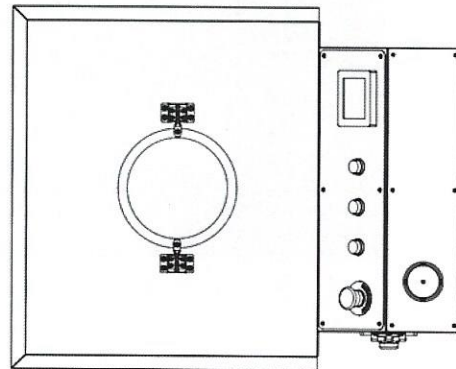

CONTAINER

Weight approx. 2.3kg

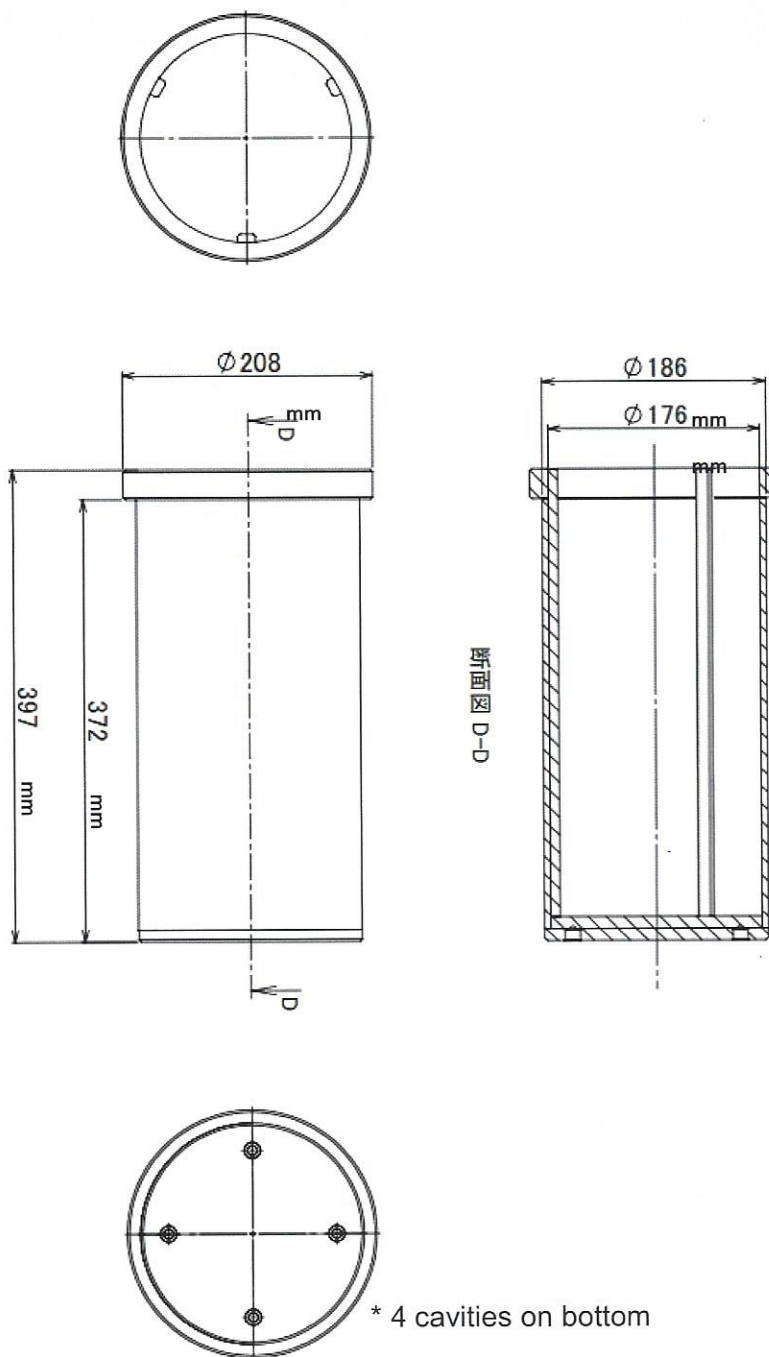

2-2-2. POWER SUPPLY

Apply power voltage 3P 230 VAC, +- 10%, 15A only.
Power consumption is 3.45kVA or less.

2-2-3. Parameter setting

Following a chart of parameter details of EM-7.

No.	Parameter	Description	Unit	Default	Range	Minimum unit
1	TPT	Total process time	mm:ss	10:00	1:00-30:00	1sec
2	RPT	Reverse process time	mm:ss	5:00	1:00-30:00	1sec
3	RS	Rotation speed setting	%	100	20-100	20
4	PP	Process pattern	-	1	1-4	1
5	AT	Acceleration time	sec	60	5-600	1
6	ST	Slowdown time	sec	60	5-600	1
7	CCWS	Counter clockwise setting; ON / OFF	-	ON	ON or OFF	-
8	BS	Buzzer Setting; ON / OFF	-	ON	ON or OFF	-
9	Memory	Memory number setting	-	1	1-10	1

* No. 4, Process pattern; EM-7 has 4 kinds of process pattern as you see below.

AT and ST will be invalid when you choose pattern 1 [Step mode]

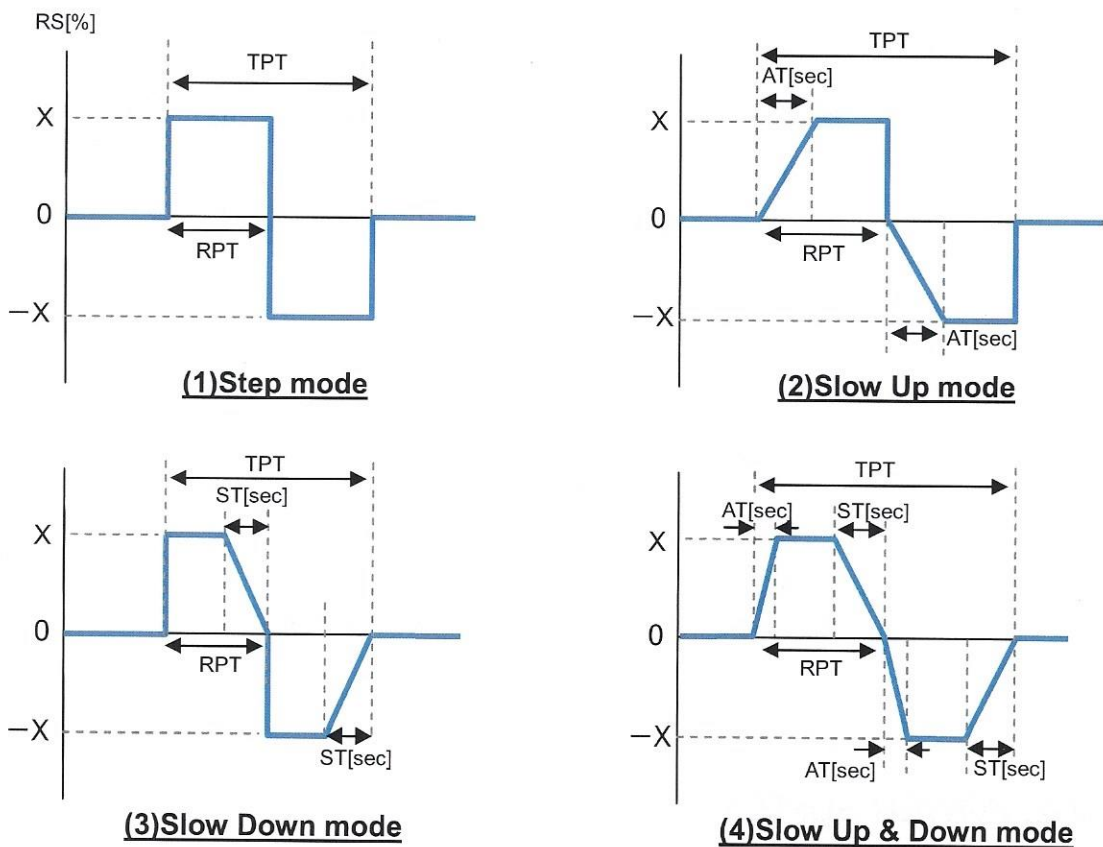

2-2-4. STATUS of progress

There are 4 kinds of status on EM-7 operation; IDLE (Standby), IDLE (Pause), RUN and ERROR.

A chart like below will appear, Signal light turns on accordingly.

Parameter edit can be done at IDLE status only.

EM-7 goes back to status IDLE (Standby) when you edit parameter at status IDLE (Pause).

- * You can refer the layout of push button switches at chapter 3-3.
- * EM-7 goes back to status IDLE (Standby) when you edit parameter at status IDLE (Pause).
- * 'Voltage Monitoring' at range of 230VAC+- 10%

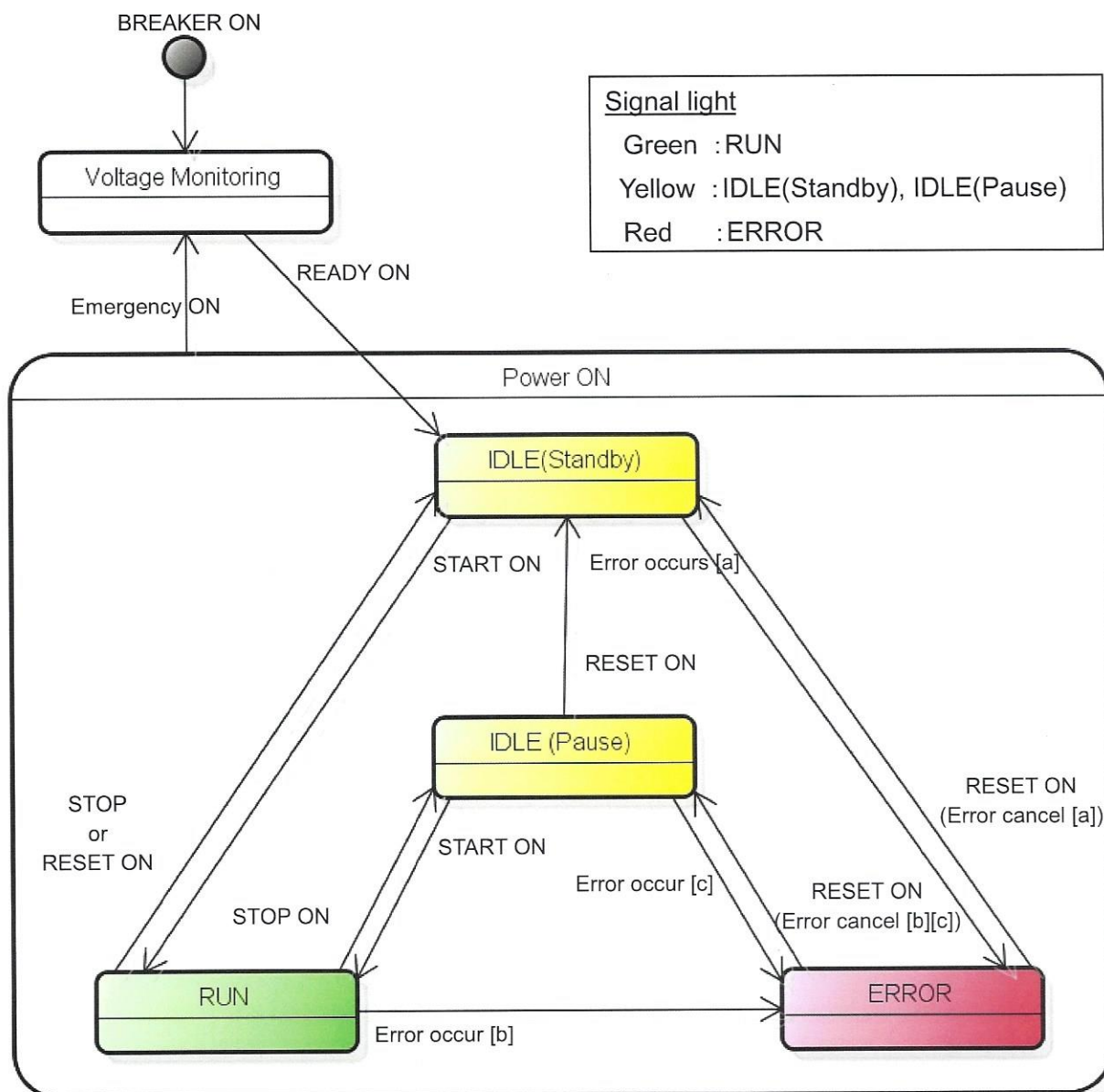

2-2-5. STATUS of progress

You can refer the following error code list when you have an error at status IDLE (Standby). Detailed information will be described at chapter 7.

Code	Incident	Description
E010	Input power anomaly	Over 3P 230V±10% (Max500V) voltage supplied. Power supply is automatically cut off, thus nothing displayed on operation panel. Check voltage monitoring relay located in control cabinet.
E020	Inverter anomaly	Inverter anomaly detected, operation suspended. Error code shown on LCD.
E021	Inverter overload	Overload on inverter detected, operation suspended. Error code shown on LCD.
E030	Temperature anomaly	Abnormally high temperature over 120 degrees Celsius detected inside of machine body, Operation suspended until cooled down to lower than 80 degrees Celsius. Error code shown on LCD.
W010	Overheat	Warning indicated on LCD when temperature inside of machine body got over 80 degrees Celsius. Error code shown on LCD. Only warning and no suspension on operation.

2-2-6. WORKING CONDITIONS

- 1) Use this product at temperatures ranging 0-40 degrees Celsius and humidity under 70%.
- 2) Do not use this product under atmosphere with too much dust or with harmful gas.



WARNING

Check and read chapter 1 and 4-2-1

3. NOMENCLATURE

3-1. OUTSIDE VIEW

EM-7 consists of body, operation panel and control cabinet.

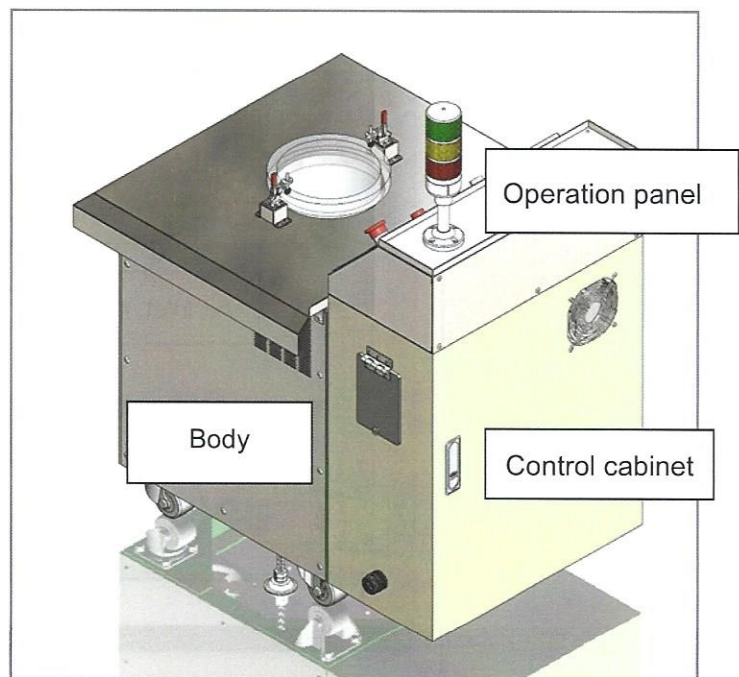
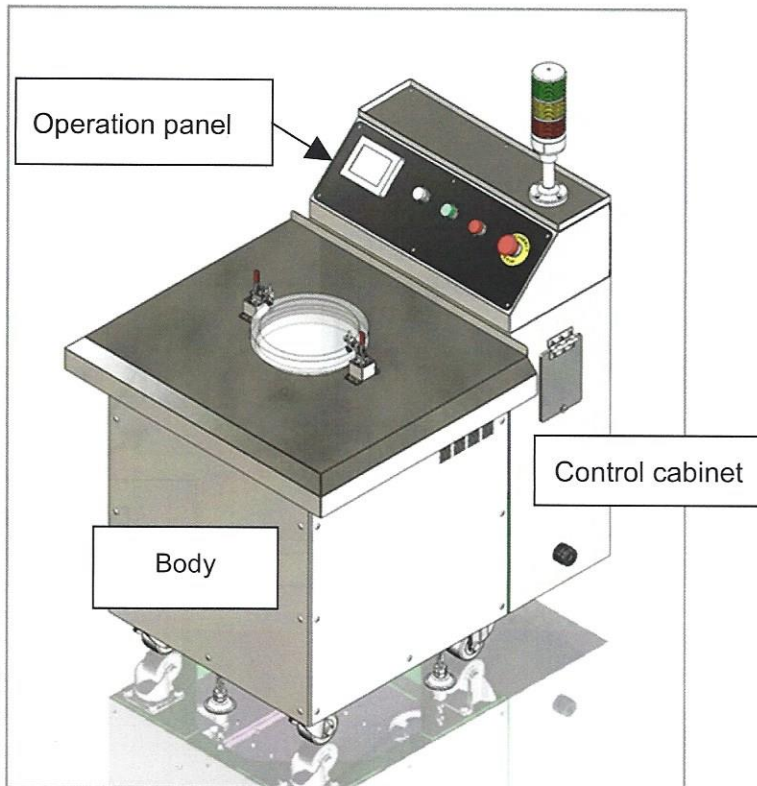

3-2. BODY

There is a pit for container at the center of machine table.

There are two dowel pins on the bottom of pit so that gaps on container will fit on it.

Container should be fixed by two fixing fittings.

There are 4 air inlets on the bottom of body, 2 exhaust ports on right and left side of body.

4 casters and 3 level adjusters on the bottom.

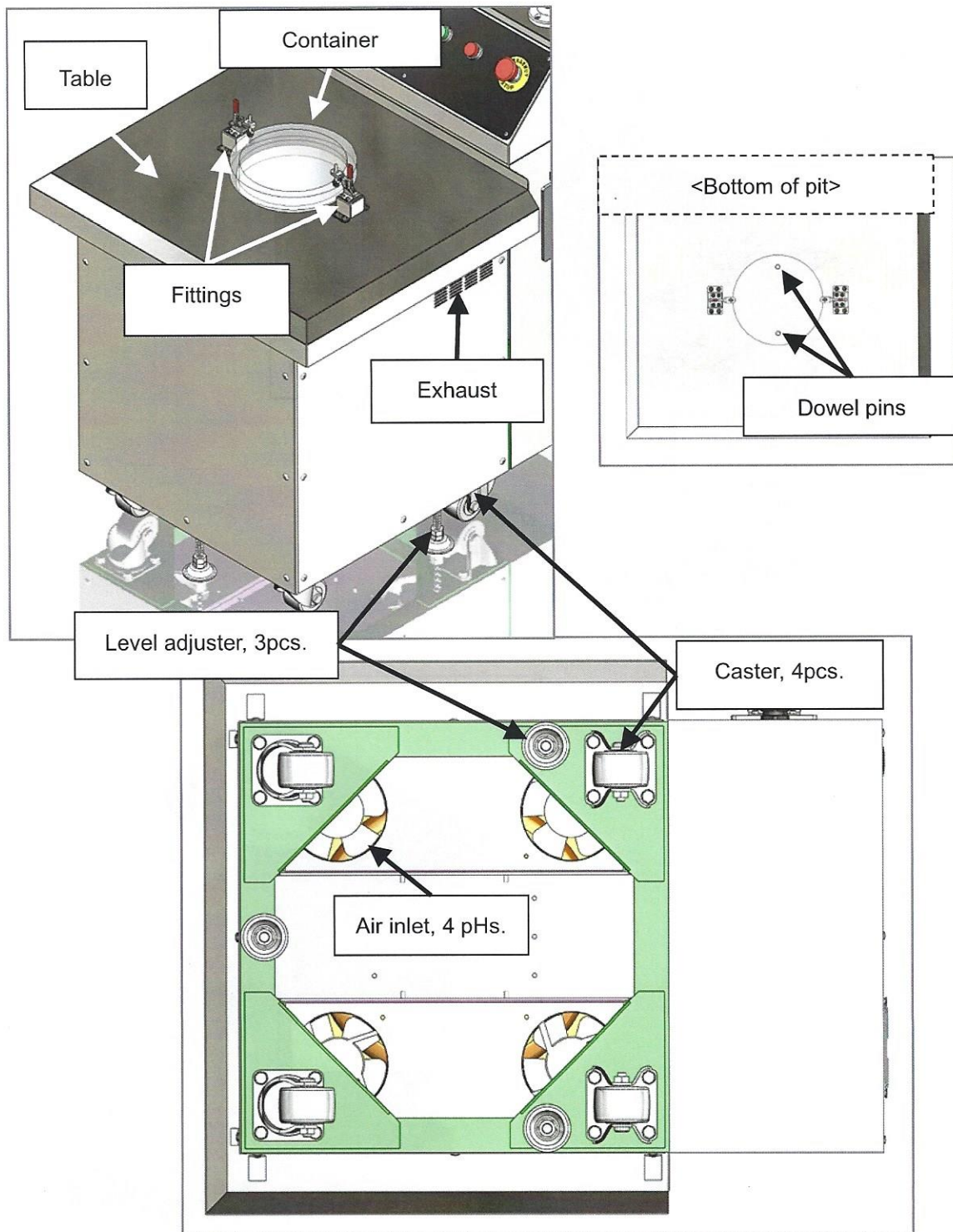

3-3. OPERATION PANEL

There is LCD touch panel and push button switches on operation panel.

Metal pan and signal light on top of control cabinet.

Both parts must be kept away from water.

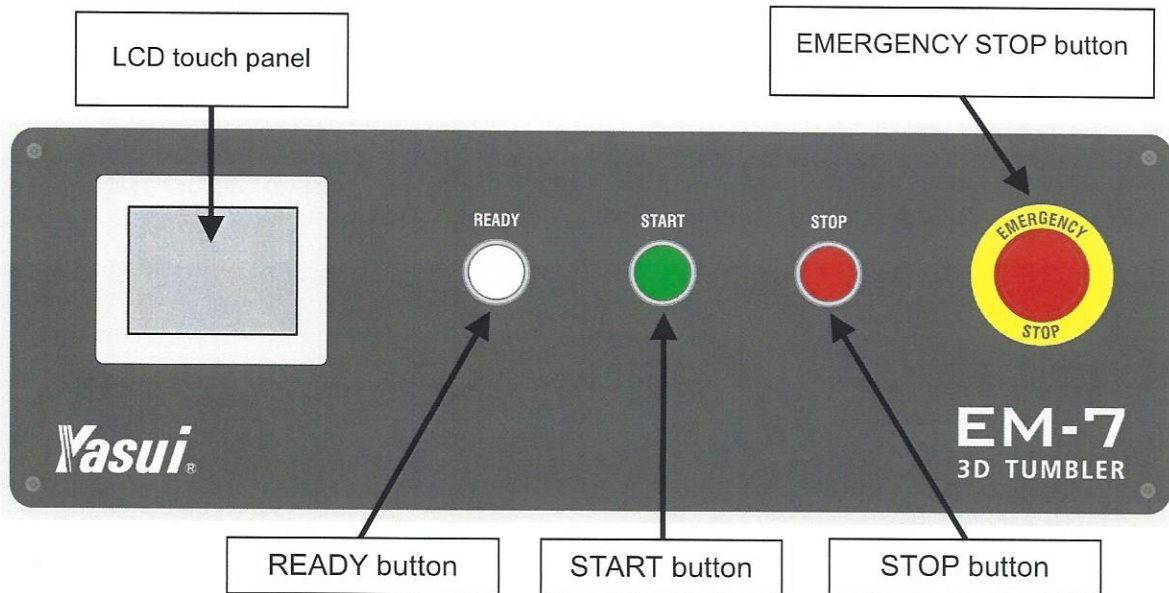
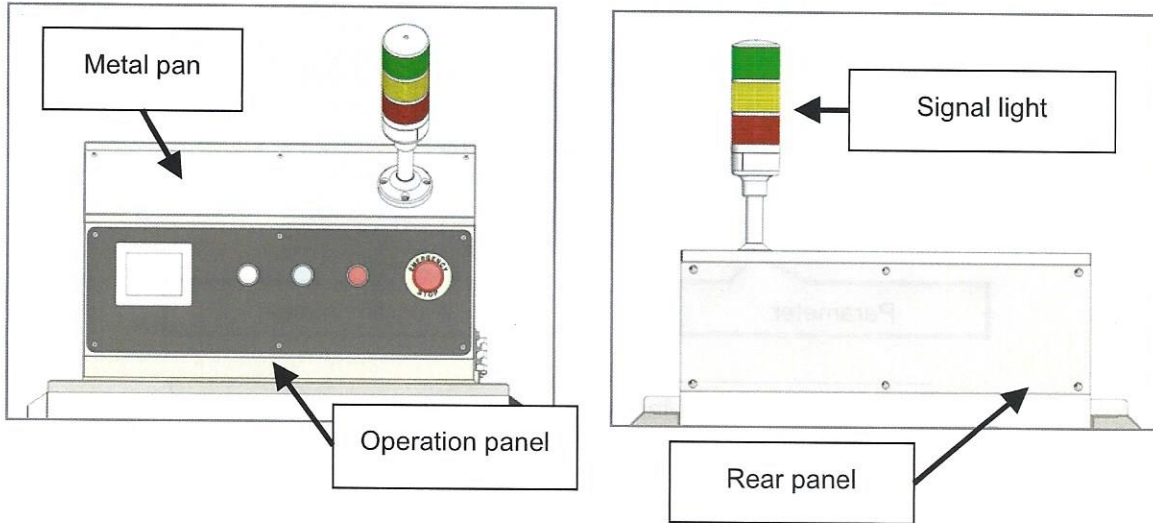

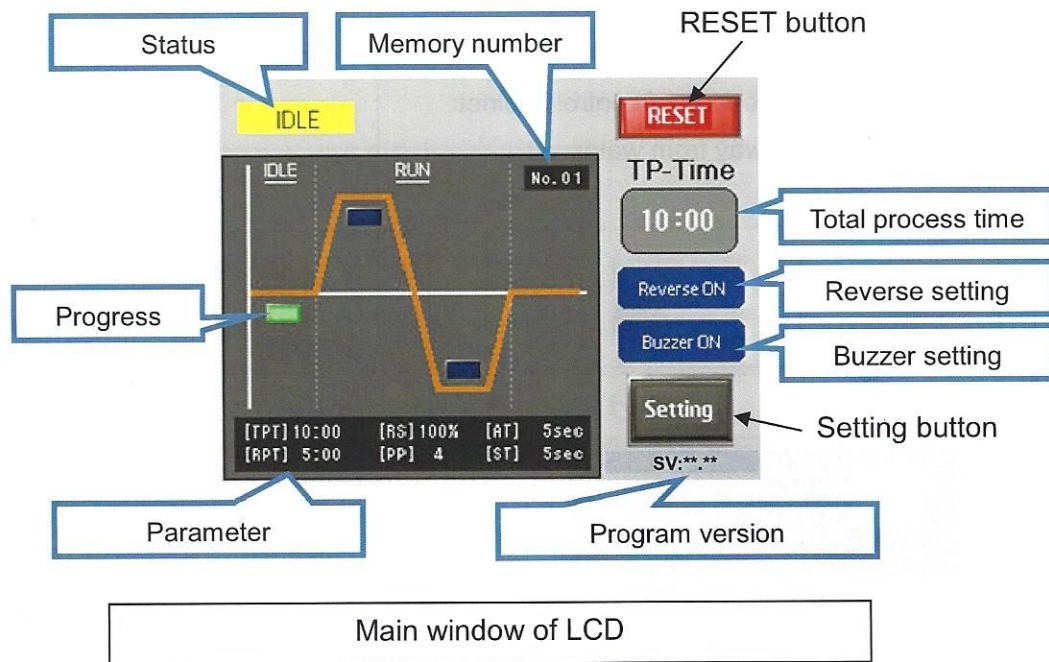

3-4. CONTROL CABINET

Open control cabinet when you have a problem on electricity.

You can check voltage monitoring relay.

Read chapter 7 for detailed information.

A key for control cabinet is stuck inside.

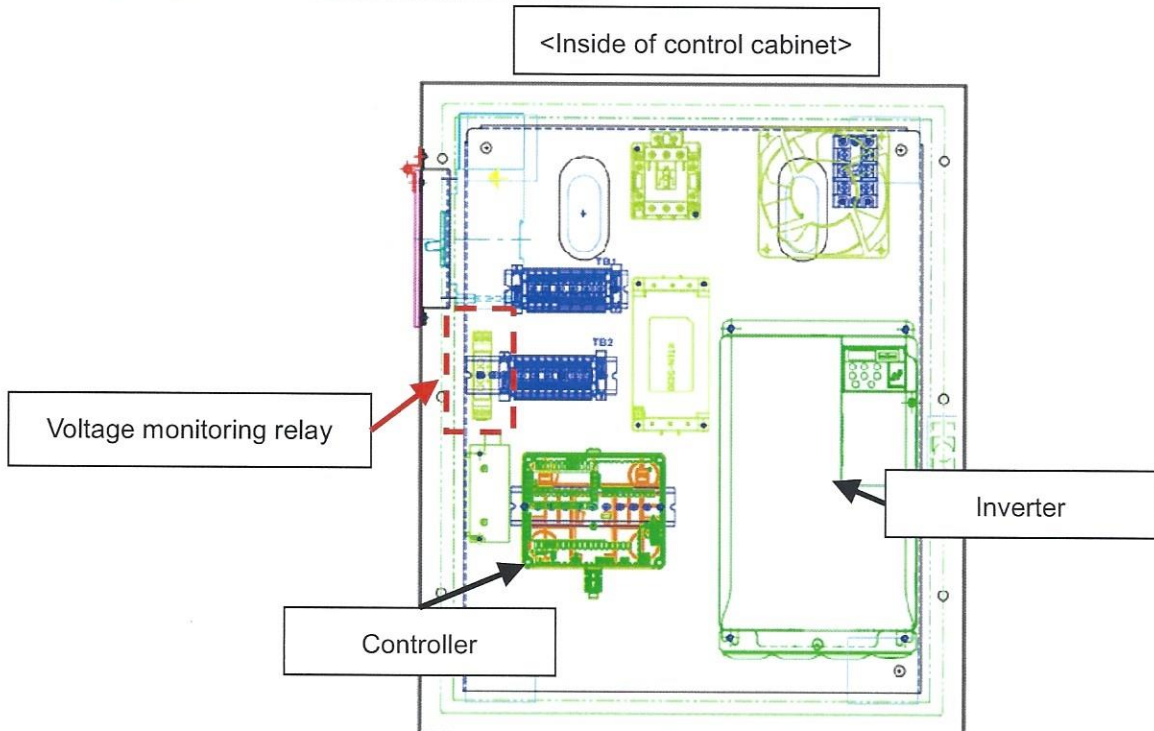
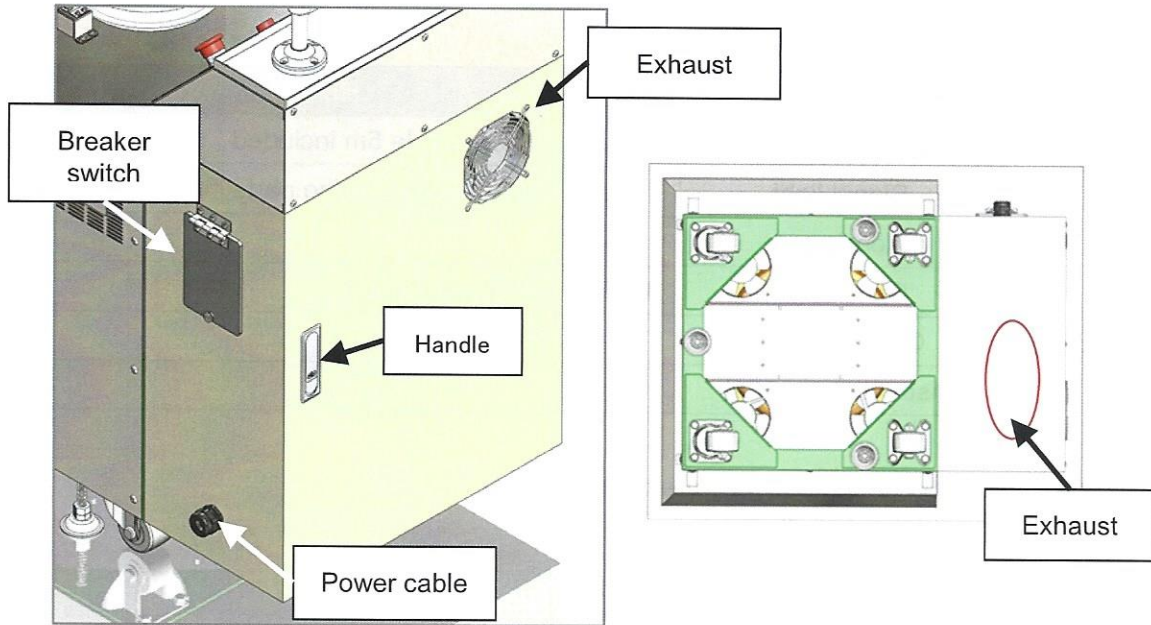

4. INSTALLATION

4-1. ACCESSORIES

EM-7 consists of those accessories below.

Check everything included in the carton when installation.

Item	Q'ty	Remarks
Main body (EM-7)	1 pc	Power cable 5m included
Signal light	1 set	Rubber base, fixing parts included
Acrylic pot	1 pc	
Compound	4 liters	All-in-one type
Quick manual	1 pc	This book
Instruction manual	1 pc	

No polishing media is listed as they are optional items.

4-2. INSTALLATION

4-2-1. WORKING CONDITIONS

Keep following working conditions at installation.

Pay attention on very strong magnetic field which is generated by EM-7.

Do not wear watches and other sensitive devices against magnetic power when working on EM-7.

< Working conditions >

- 1) Floor must be sturdy and stable, free from vibrations, water and dust.
- 2) Machine must be leveled. (When floor is not flat, adjust level adjuster, so that the machine should be leveled.)
- 3) Indoors where not so much high temperature and humidity without direct sun light.
- 4) Place which does not have any corrosive gases.
- 5) No flammable gases like acetylene gas nearby.
- 6) Nothing affected by strong magnetic field nearby.
- 7) Must be away from children and animals.
- 8) Must have enough space around machine body for cooling fan.



WARNING

Check and read chapter 1 and 2-3-6

4-2-2. WORKING CONDITIONS

* There are 3 level adjusters as marked below, Check body is fixed by them;

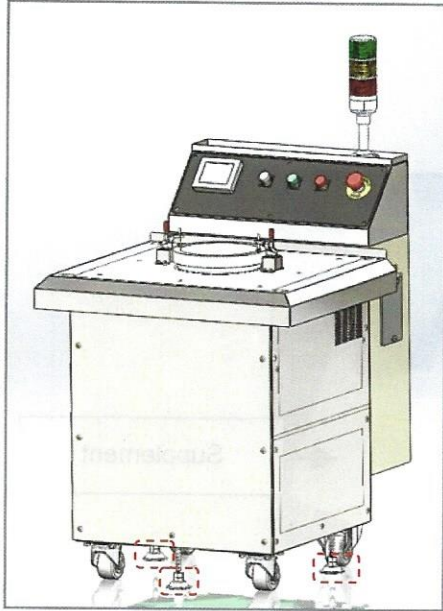

Level adjuster

使用例
Example of application



機器設置後の高さ調節が容易です。
It's easy to adjust level after
installation.

4-2-3. SIGNAL TOWER

Install signal light following the instruction (Operation can be done without this light)

< How to install >

- 1) Read supplement attached on operation cabinet.
Unpack signal light as well.

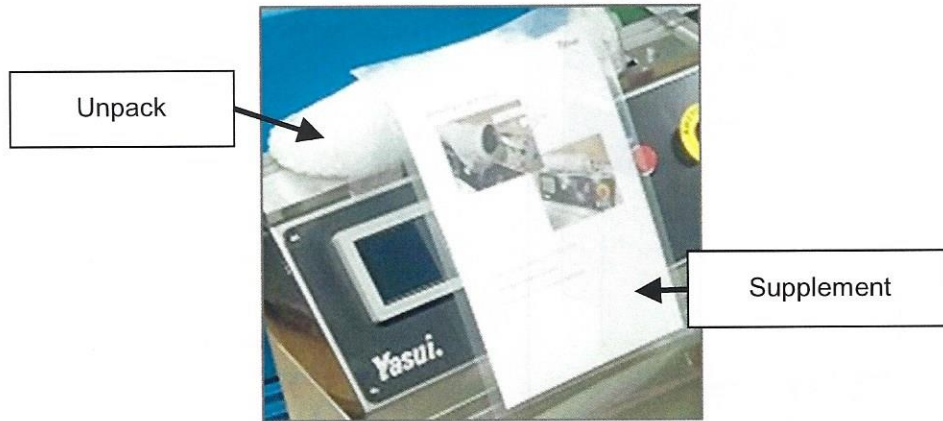

- 2) Remove 4 screw bolts on cabinet to fix signal light
Pay attention on cable of signal light.

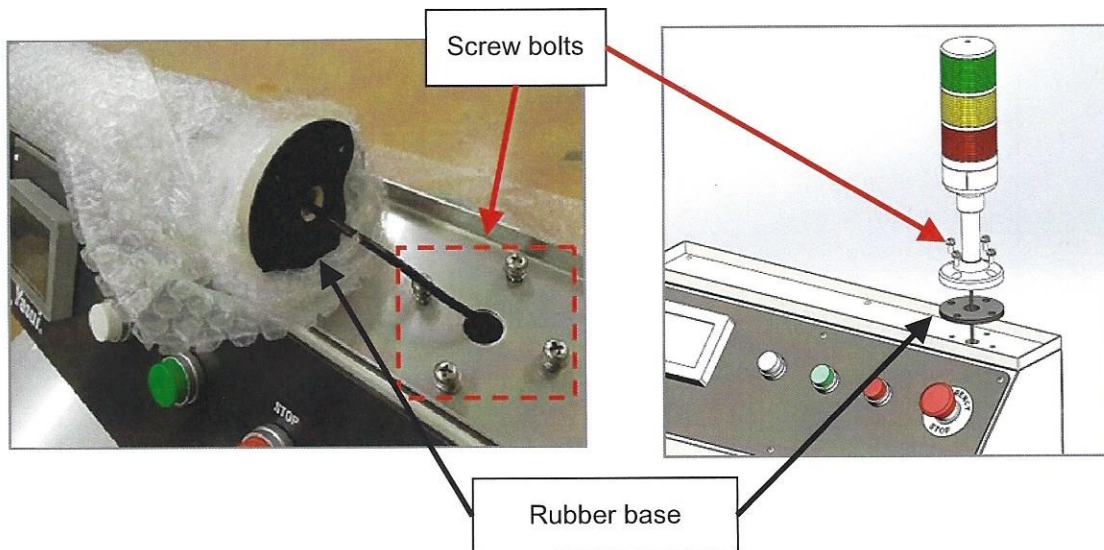

4-2-4. POWER CABLE

- Check breaker switch on the right of body is turned off.

Connect cable to power supply 230VAC, 3 phase, 15A.

Cable colors are described as below;

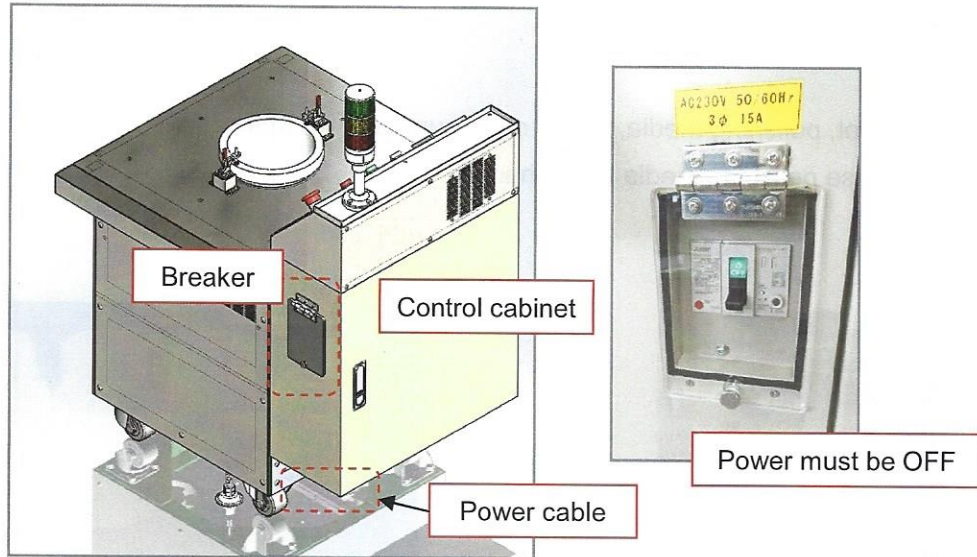

EM-7 Power cable color and phase

Phase	Color
R/L1	Red
S/L2	white
T/L3	Black
E	Green

* Cable size : 5.5(Sq)

WARNING

Connect cables onto correct phase with correct voltage

4-3. TRANSPORTATION

3 level adjusters must be completely lifted up when you move this product.

Breaker switch must be turned OFF, plug must be removed from outlet.

You must be sure of safety before operation.

Remove signal light with the opposite process at installation when transfer to another place.

5. OPERATION

5-1. POLISHING

1) PREPARATION

- Prepare Acrylic pot, polishing media, water, compound and workpieces.
Choose and purchase polishing media beforehand.

Acrylic pot



Polishing media



Compound



Work pieces



* You can measure compound using cap of bottle; a cap of compound is 15cc.

- Put media, water, compound and workpieces into acrylic pot.
- Reference amount of them as follows;

Workpieces	:	up to 2kgs.
Media	:	1.5 - 3kgs.
Water	:	3 - 6 liters.
Compound	:	10 - 30cc.

* Compound water solution is disposable like a kitchen detergent.

* Always put over 1.5kgs of media to prevent EM-7 show error [E021]

Water level should be over 60% of the pot.

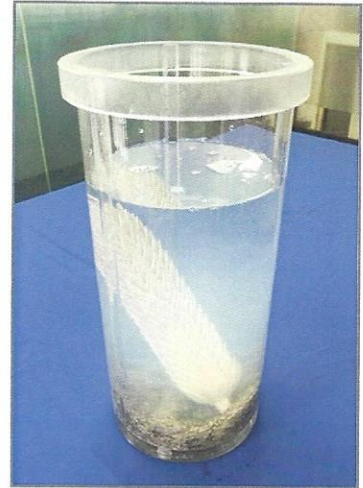

- Check fixing fitting is set on unlock position.

Put acrylic pot so that two gaps fit dowel pins on the bottom of chamber.

Check acrylic pot does not rotate and fix it by fittings.

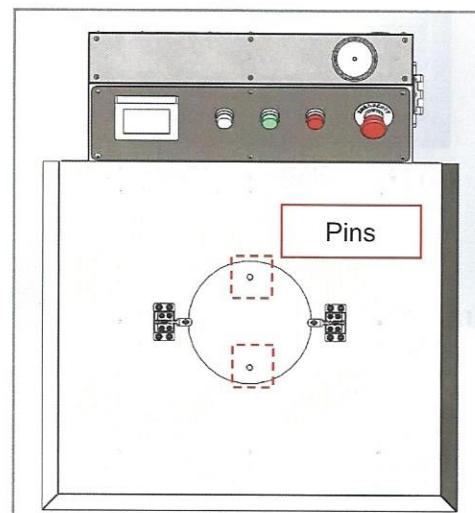
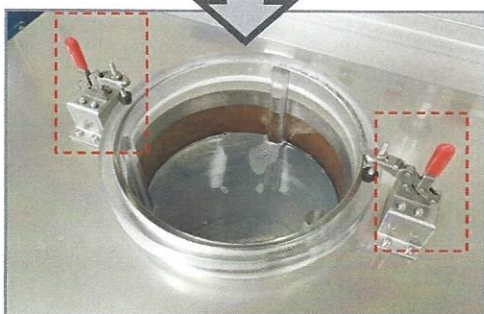
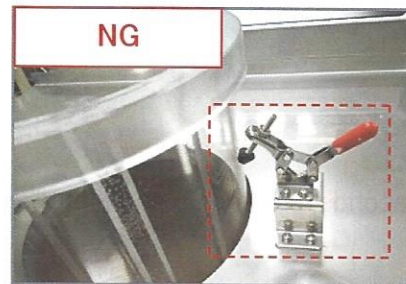

2) STARTING UP EM-7

- Turn breaker ON

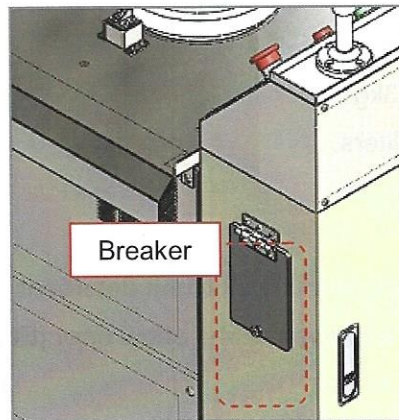

- Push [READY] button on operation panel. LCD turns on as following step.



After 15 seconds, starting up completed and you will see the window (a) or (b) on LCD as follows;

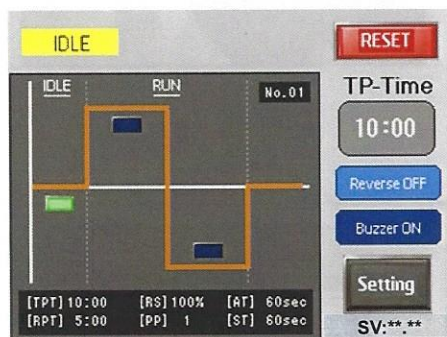

(a) Main window 1 [Default setting]

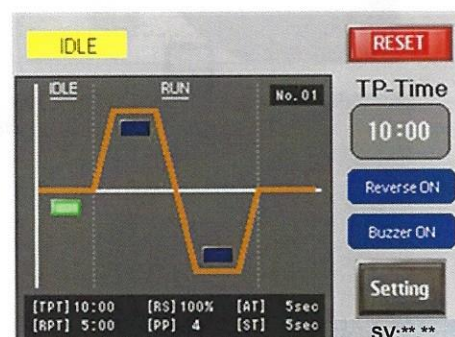

(b) Main window 2

3) Parameter setting and operation

- Set parameters.
- Push [START] button.

* Refer Chapter 2-3 for details of parameter setting and operation.

4) Separating workpieces

- Release fittings on acrylic pot to take it out.
- Check polishing result and wash acrylic pot and media.

Use plastic bowl and sieve for faster handling.

WARNING
Careful not to be burnt

<Separating casting tree>

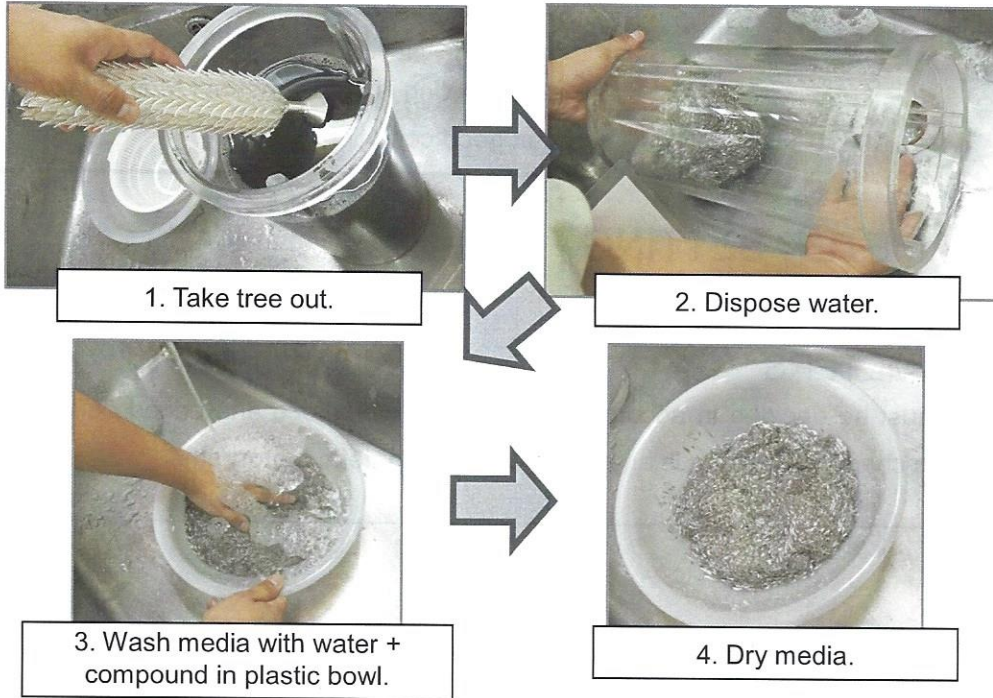

<Separating small workpieces>

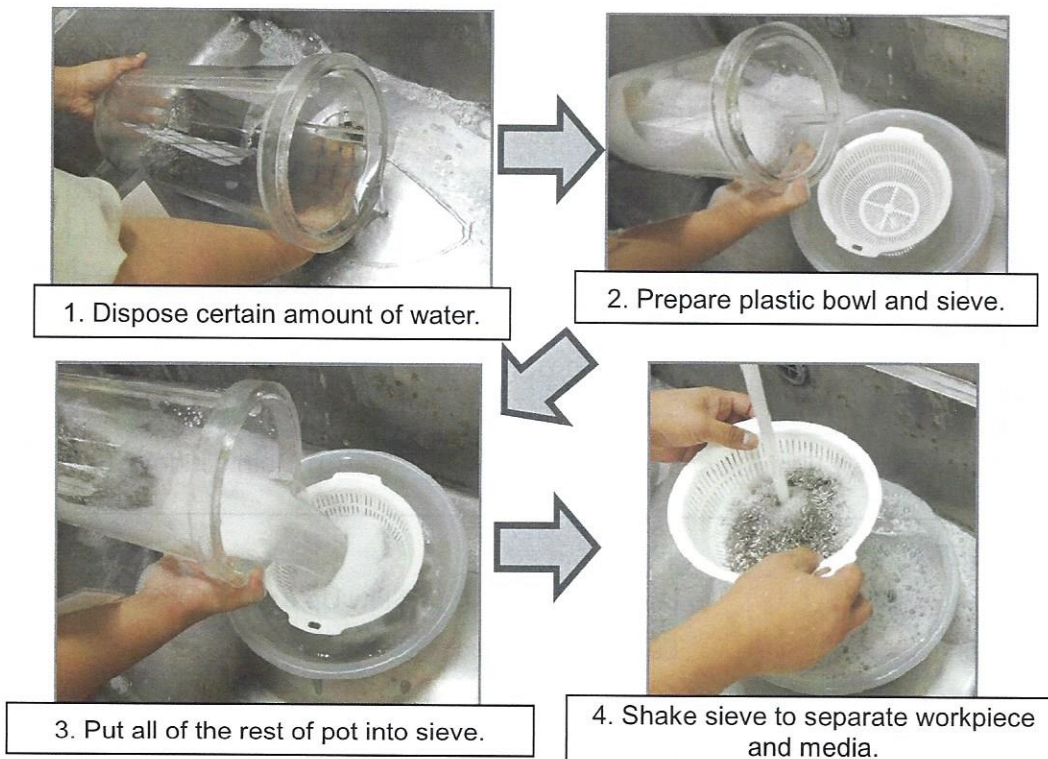

Wash and dry media, following step 3 and 4 of <Separating casting tree>.

5) Suspending operation

- Leave machine at IDLE status for approx. 10 minutes after process time up.
Keep leaving for more than 30 minutes when you see a warning message [W010] on the display.
This warning can be shown when you operate very long time.

- Turn off breaker switch when the warning is not indicated

Confirm the status is on IDLE before turning off.

WARNING
Air cooling is very important to maintain machine in good condition.

5-2. PARAMETER SETTING

5-2-1. PARAMETERS

- Parameters must be decided in accordance with each workpiece and edited default program on LCD as following chart; Following is an example of editing default program.

CAUTION:

Those 3 buttons on LCD must be pressed down longer to enter.

[RESET] button : 0.5 second, [Setting] button : 0.5 second, [SAVE] button : 2 seconds.

Do not give irregular operations, like long press on several buttons at the same time.

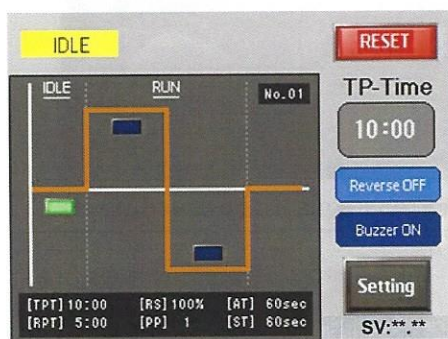

(a) Main window1 [Default setting]

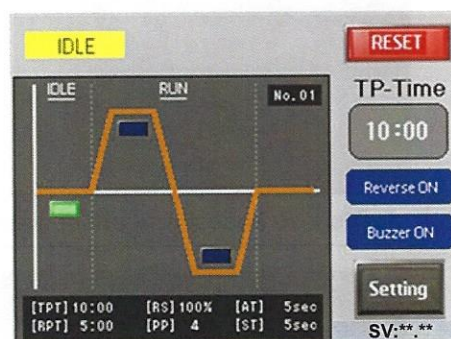

(b) Main window 2

< RECIPE IN DETAIL >

- PP(Process pattern) : (1)Step mode → (4)Slow Up & Down mode
- AT(Acceleration time) : 60 sec. → 5 sec.
- ST(Slowdown time) : 60 sec. → 5 sec.
- CCWS(Counter clockwise setting) : Invalid → Valid

< Example of setting >

- Push down [Setting] button for 0.5 second to move onto [Setting 1] window from Main window.
- Maintain Memory number 1. If you need to change it, push [Memory No. 01] button to activate key board and edit number, push [Enter] and [Exit] button.
- Push [PP] (Process pattern) button to go to [Setting 1-4] window.

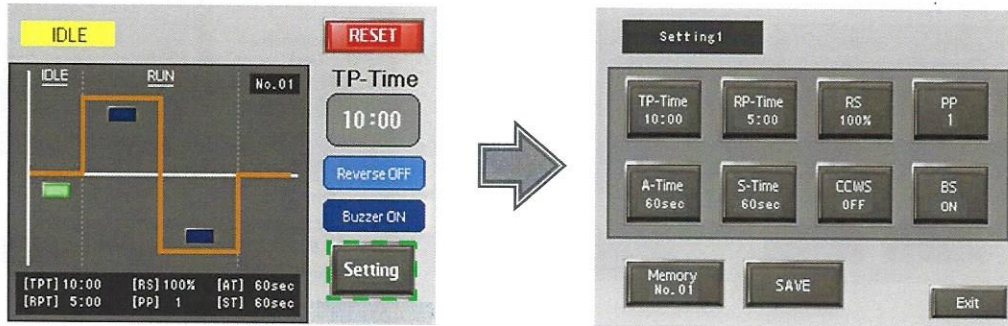

- Push [4], [Enter], and [Exit] button on key board. (Do not press at once)
- Push [A-Time] (Acceleration time) button to go to [Setting 1-5] window.

* Step mode; Standard process pattern, just rotation on and off at setting speed.
 * Slow Up & Down mode; Rotation on and off with acceleration and slowdown speed controlled.
 You can refer the detail at chapter 6.

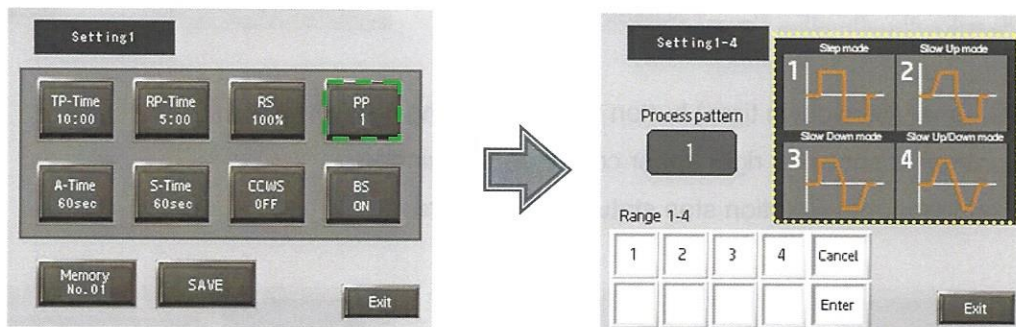

- Push [4], [Enter], and [Exit] button on key board. (Do not press at once)
- Check if PP4 is selected at Setting1 window.

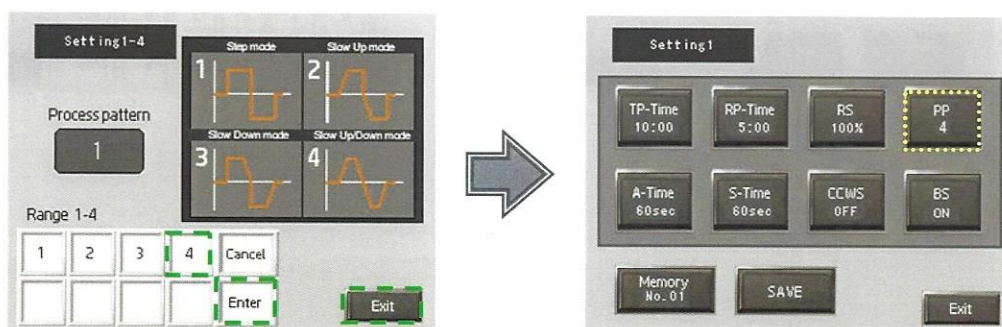

- Push [A-Time] (Acceleration time) button to go to [Setting 1-5] window.
- Push [ON] button and [Exit] button on the window. (Do not press at once)

Process pattern is shown at right upper corner on the window.

You can set timer upto Rotation speed by key board.

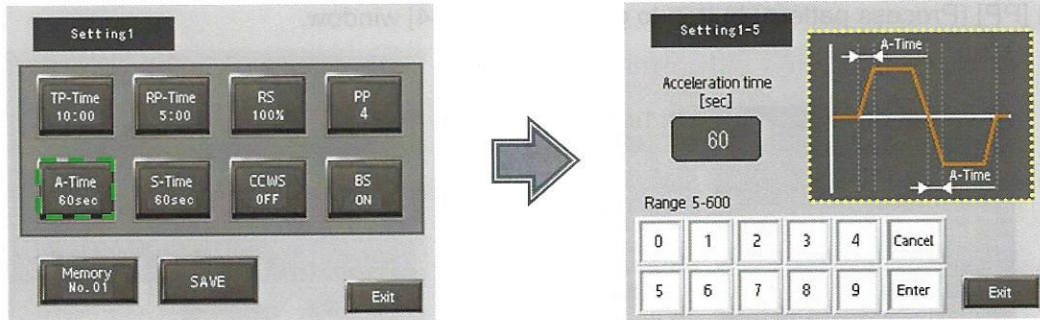

- Push [5], [Enter], and [Exit] button on key board. (Do not press at once)
- Check [A-Time] is set 5 sec. at Setting1 window.

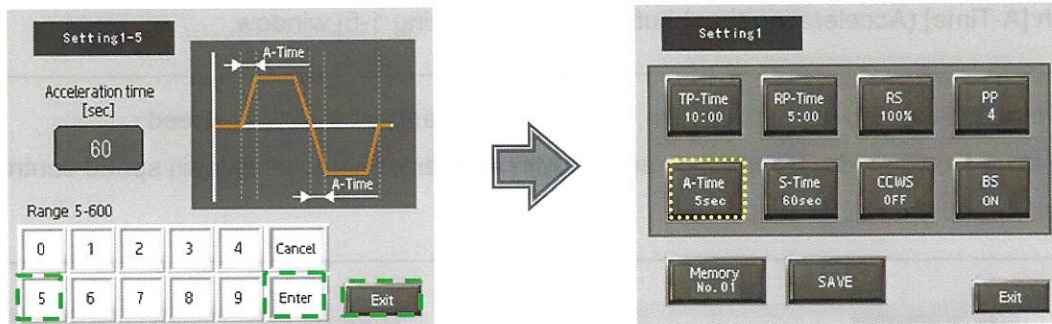

- Push [S-Time] (Slowdown time) button to go to [Setting 1-6] window.

Process pattern is shown at right upper corner on the window.

You can set timer upto Rotation stop status by key board.



- Push [5], [Enter], and [Exit] button on key board. (Do not press at once)
- Check [S-Time] is set 5 sec. at Setting1 window.

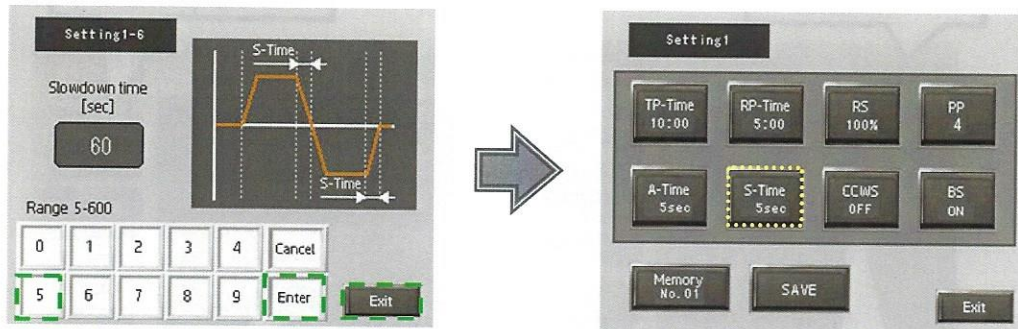

- Push [CCWS] (Counter clockwise setting) button to go to [Setting 1-7] window.
- Push [ON] button and [Exit] button on the window. (Do not press at once)

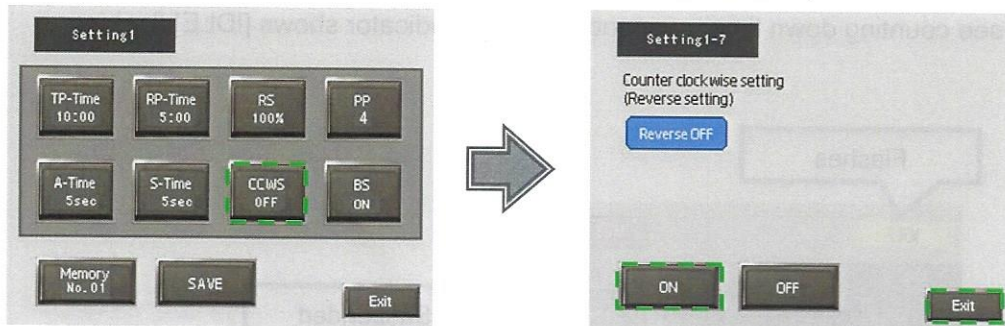

- Check if parameter edit has been done correctly at [Setting 1] window.
- Push down [SAVE] button for 2 seconds to determine new program.

The present Memory is now overwritten.

- Push [Exit] to finish parameter setting and go back to [Main] window.

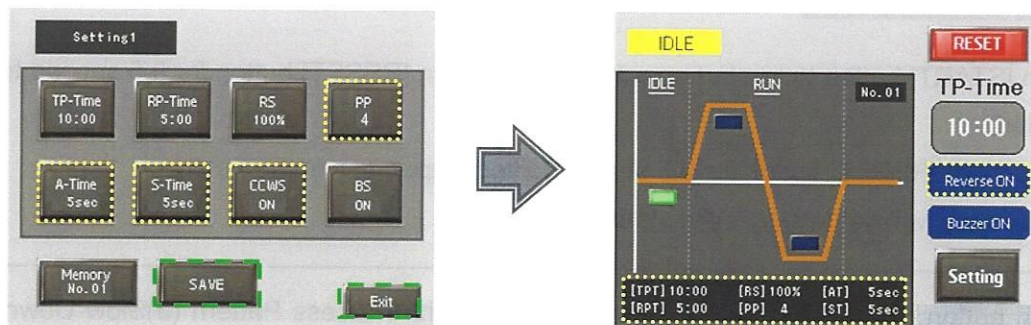

5-2-2. OPERATION

- Push [START] button on operation panel to start polishing.
- Status indicator shows [RUN], Magnetic field starts rotation clockwise.

Rotation will be changed to counter clockwise by timer 5 minutes later.

The default time setting 5 minutes can be changed by the range of 1 to 30 minutes.

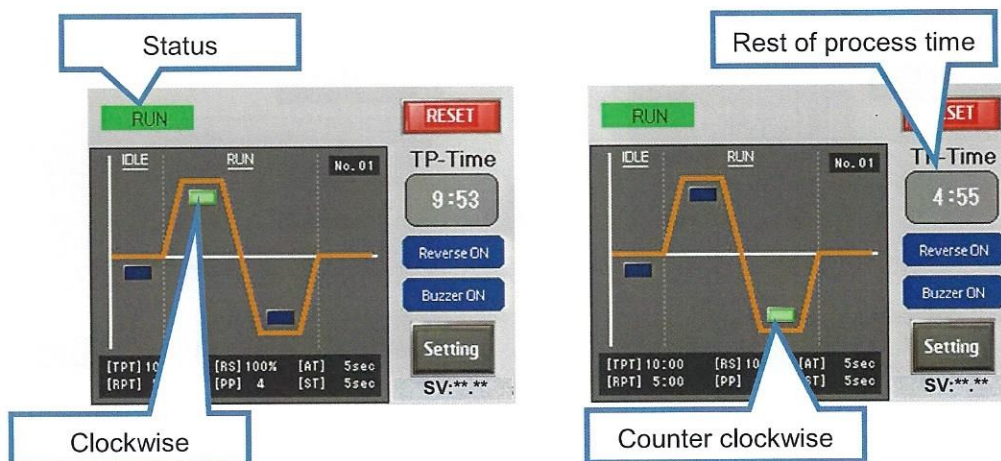

- Push [STOP] button on operation panel to suspend operation. You will see counting down timer suspended. Status indicator shows [IDLE] flashing.

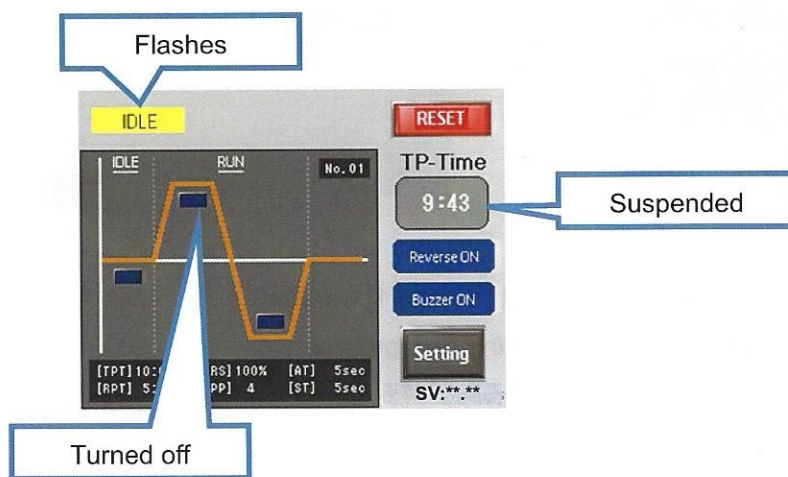

- Push [START] button to re-start operation, Push down [RESET] button for 0.5 second to finish operation.
- Push down [RESET] button for 0.5 second to finish operation immediately.
- The window will go back to initial status [IDLE].

** Each button reacts as follows when you operate with Process Pattern (3)Slow Down mode and (4)Slow Up & Down mode.

STOP : Operation immediately paused.

RESET : Operation stops following Slowdown Time setting.

STOP and RESET for immediate going back to IDLE (Standby) status.

6. ADVANCED OPERATION

6-1. PARAMETER SETTINGS

6-1-1. TPT (Total Process Time)

No.	Parameter	Description	Unit	Default	Range	Minimum unit
1	TPT	Total process time	mm:ss	10:00	1:00-30:00	1sec

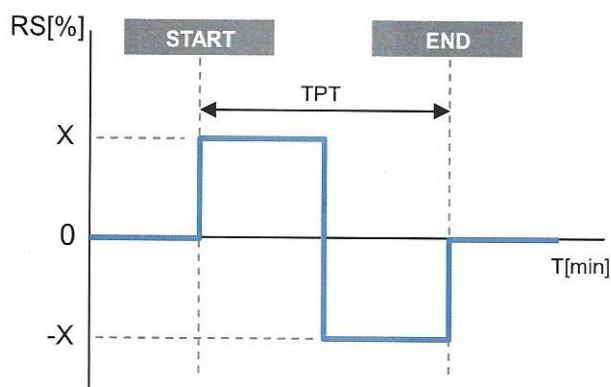

TPT is time from operation [START] to the end.

Default setting value is 10 minutes and the range is 1 to 30 minute with minimum unit 1 second.

Time unit is shown as mm:ss.

Recommended setting time is ten minutes for jewelry product in general.

< How to edit >

- Push down [Setting] button for 0.5 second to move onto [Setting 1] window from Main window. You always need to open this window when you edit parameter.

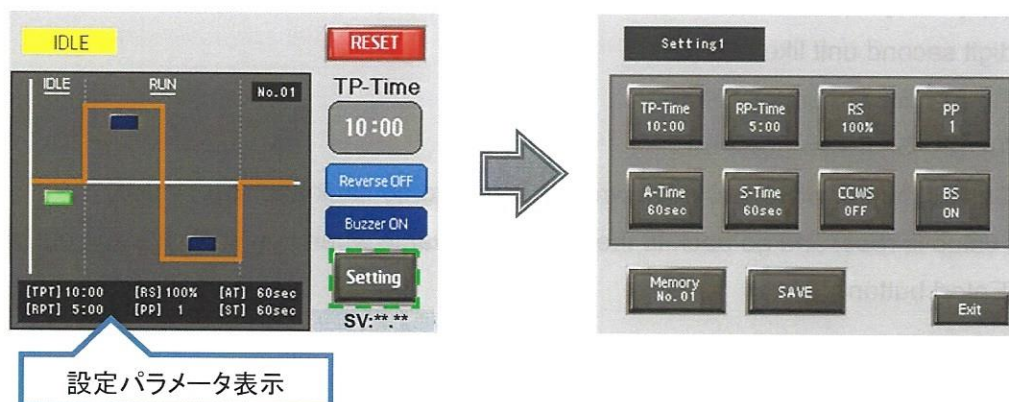

- Push [TP-Time] (Total process time) button to go to [Setting 1-1] window.

Chart of TPT is shown at right upper corner, Setting Value at present at left side on the window.
Range is shown below the setting value.

- Push [2], [0], [Enter] button on key board when you edit TPT from 10:00 to 20:00.

Push [Exit] button to go back to [Setting 1] window to double check the setting is surely changed.

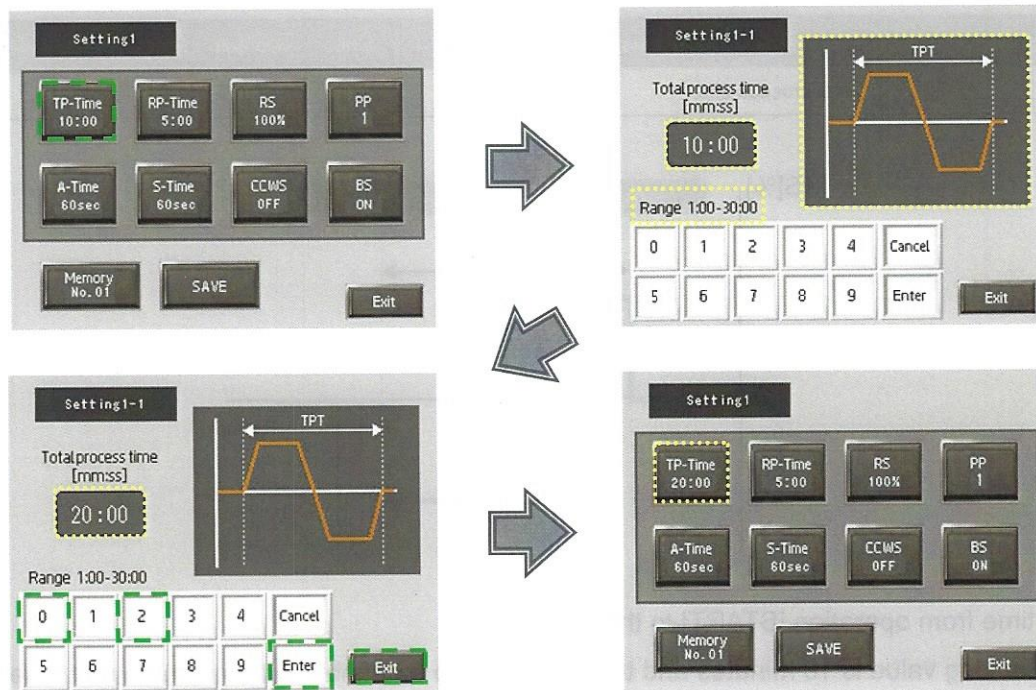

* Time unit is shown as mm:ss and you have to enter as following step;

Push [1], [2], [2], [5], [Enter] for 12:25.

Push [0], [7], [2], [5], [Enter] for 7:25.

* You can skip pushing key board when second unit is 0;

Push [1], [0], [Enter] for 10:00.

Push [2], [Enter] for 2:00.

* Edit 1 digit second unit like this;

Push [1], [0], [5], [Enter] for 10:05.

Push [0], [2], [5], [Enter] for 2:05.

* Push [Cancel] button when you push wrong number to go back and reset value.

* Setting value is reset and go back to the last setting value when you enter a value out of range and push [Enter] button.

6-1-2. RPT (Reverse Process Time)

No.	Parameter	Description	Unit	Default	Range	Minimum unit
2	RPT	Reverse process time	mm:ss	5:00	1:00-30:00	1sec

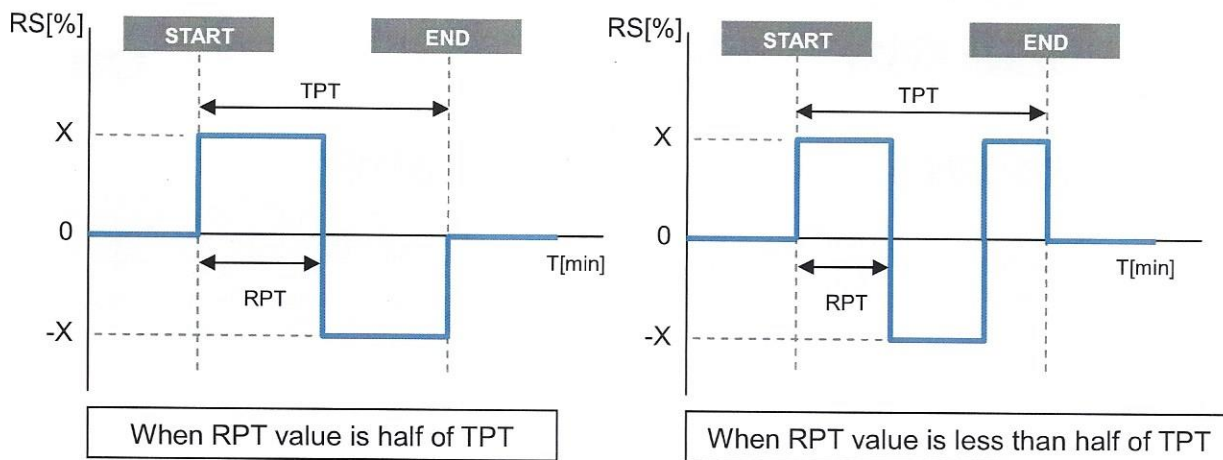

RPT is time from [START] to Reverse starts.

Default setting value is 5 minutes and the range is 1 to 30 minute with minimum unit 1 second.

Time unit is shown as mm:ss.

It reverses each time at time up of RPT when $TPT > RPT$.

Reverse rotation will be suspended at TPT.

No reverse rotation will be done when $TPT \leq RPT$.

< How to edit >

- Push down [Setting] button for 0.5 second to move onto [Setting 1] window from Main window.
- Push [RP-Time] (Reverse process time) button to go to [Setting 1-2] window.

Chart of RPT is shown at right upper corner, Setting Value at present at left side on the window.

Range is shown below the setting value.

- Push [2], [Enter] button on key board when you edit RPT from 5:00 to 2:00.

Push [Exit] button to go back to [Setting 1] window to double check the setting is surely changed.

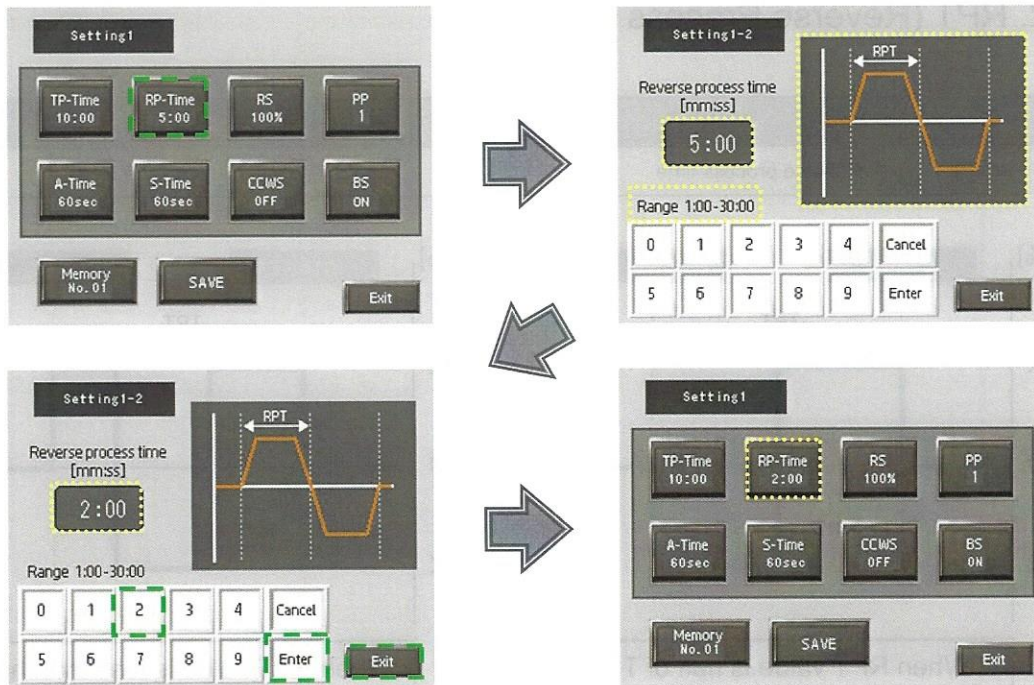

6-1-3. RS (Rotation Speed setting)

No.	Parameter	Description	Unit	Default	Range	Minimum unit
3	RS	Rotation speed setting	%	100	20-100	20

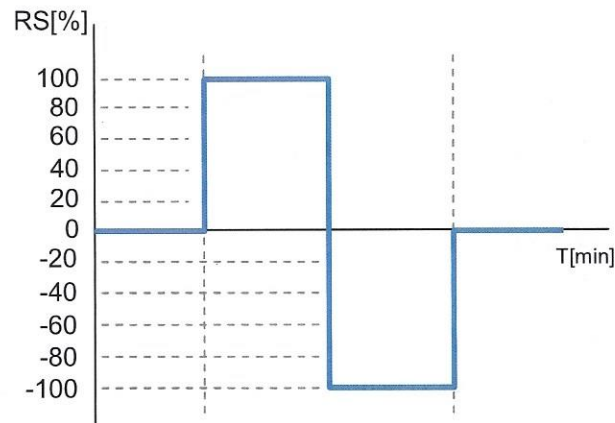

RS means rotation speed.

Default setting value is 100% and the range is 20 to 100 with minimum unit 20%.

< How to edit >

- Push down [Setting] button for 0.5 second to move onto [Setting 1] window from Main window.
- Push [RS-Time] (Rotation speed setting) button to go to [Setting 1-3] window.

Chart of RS is shown at right upper corner, Setting Value at present at left side on the window.

Range is shown below the setting value.

- Push [60], [Enter] button on key board when you edit RS from 100 to 60.

Push [Exit] button to go back to [Setting 1] window to double check the setting is surely changed.

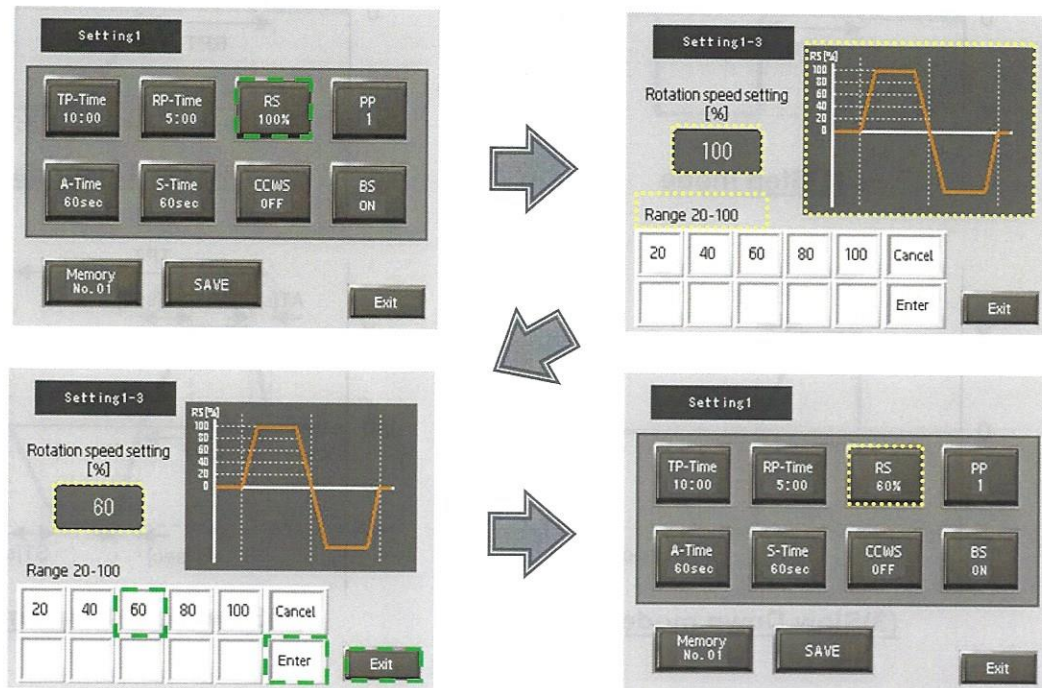

* RS cannot be set by number of rotation but choice from 5 kinds.

* The setting will be reset by [Cancel] button before [Enter].

* There can be no actual rotation activated when you choose 20% RS depending on what is in container.

You have to increase the amount of media and water at the problem.

6-1-4. PP (Process Pattern)

No.	Parameter	Description	Unit	Default	Range	Minimum unit
4	PP	Process pattern	—	1	1-4	1

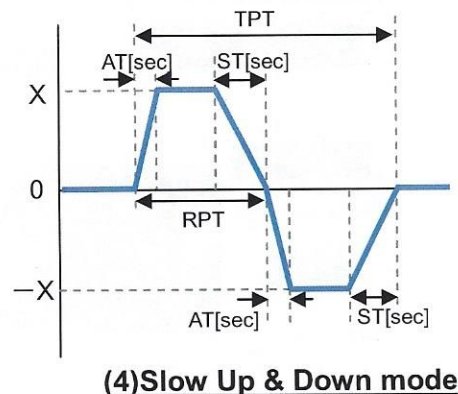
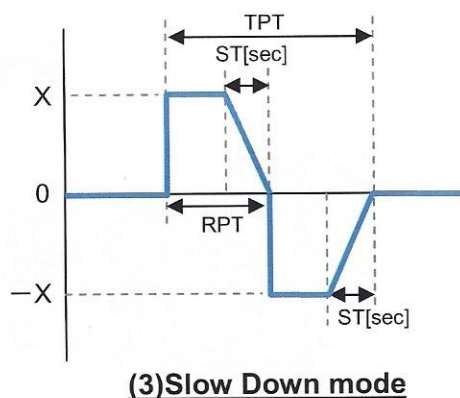
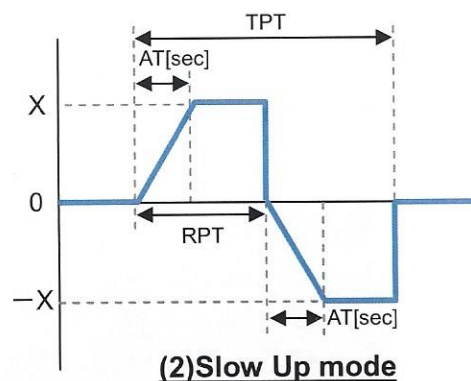
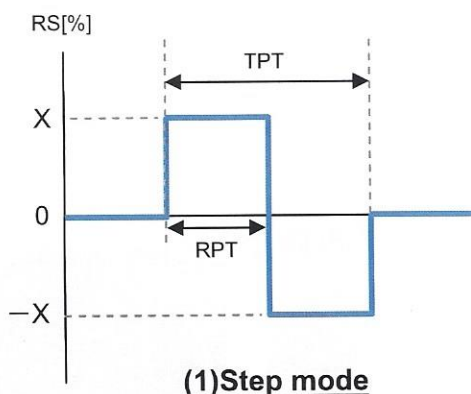

PP means 4 kinds of process patterns and default setting is (1) Step mode.

(1) Step mode

Standard process pattern, just rotation on and off at setting speed.

Most of polishing can be done by this pattern, especially effective for big workpieces with flat surface.

(2) Slow Up mode

You can control time to reach setting speed (AT).

It will immediately stop when RPT and TPT over.

Slow Up mode is especially designed for stone set casting workpieces and workpieces with fine engravings and patterns on surface.

(3) Slow Down mode

You can control slow down speed when stopping at RPT and TPT over.

(4) Slow Up & Down mode

< How to edit >

- Push down [Setting] button for 0.5 second to move onto [Setting 1] window from Main window.
- Push [PP-Time] (Process Pattern) button to go to [Setting 1-4] window.

Chart of PP is shown at right upper corner, Setting Value at present at left side on the window.

Range is shown below the setting value.

- Push [2], [Enter] button on key board when you edit PP from 1 to 2.

Push [Exit] button to go back to [Setting 1] window to double check the setting is surely changed.

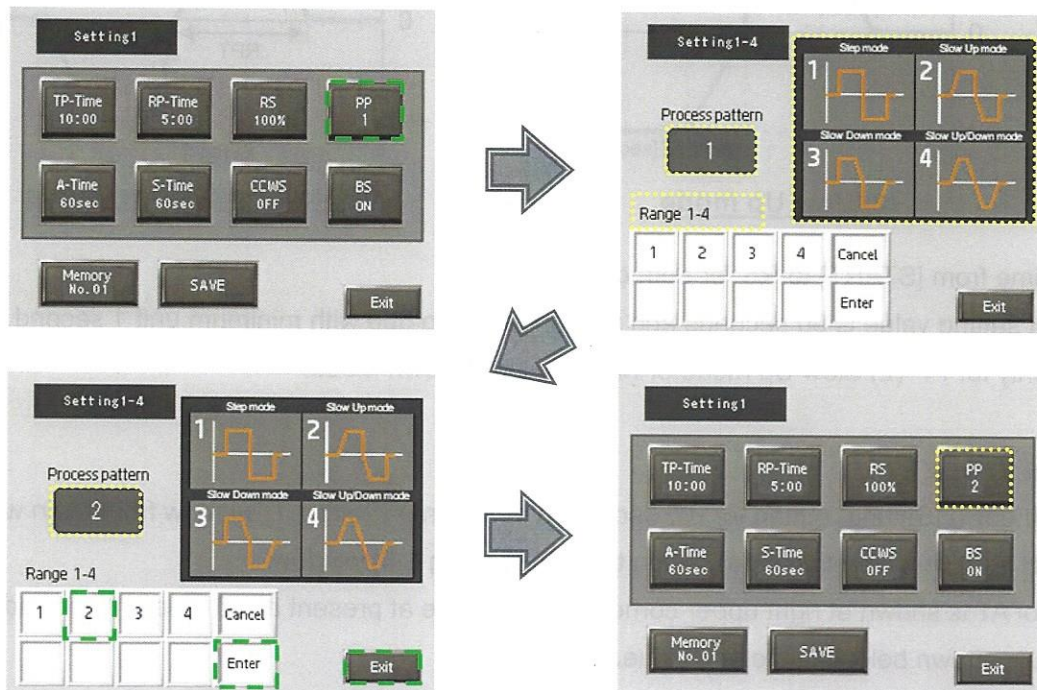

* There are 4 kinds of Process Pattern to choose.

* The setting will be reset by [Cancel] button before [Enter].

6-1-5. AT (Acceleration Time)

No.	Parameter	Description	Unit	Default	Range	Minimum unit
5	AT	Acceleration time	sec	60	5-600	1

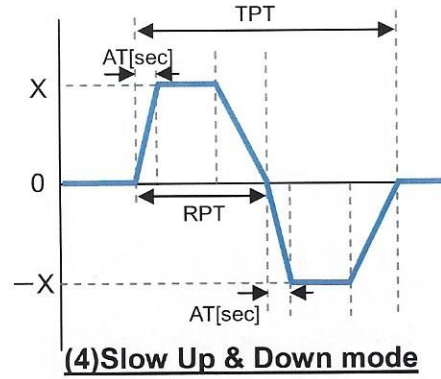
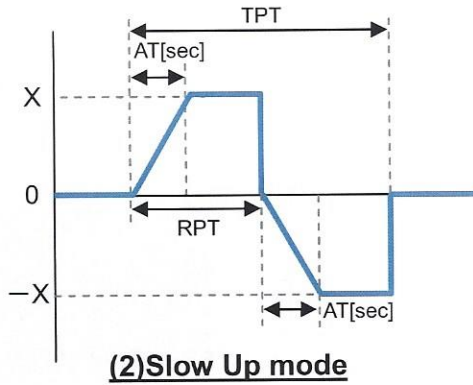

AT is time from [START] to RS for both directions.

Default setting value is 60 seconds and the range is 5 to 600 with minimum unit 1 second.

Valid only for PP (2) Slow Up mode or (4) Slow Up & Down mode.

< How to edit >

- Push down [Setting] button for 0.5 second to move onto [Setting 1] window from Main window.
- Push [AT] (Acceleration time) button to go to [Setting 1-5] window.

Chart of AT is shown at right upper corner, Setting Value at present at left side on the window.

Range is shown below the setting value.

- Push [1], [0], [Enter] button on key board when you edit AT from 60 to 10.

Push [Exit] button to go back to [Setting 1] window to double check the setting is surely changed.

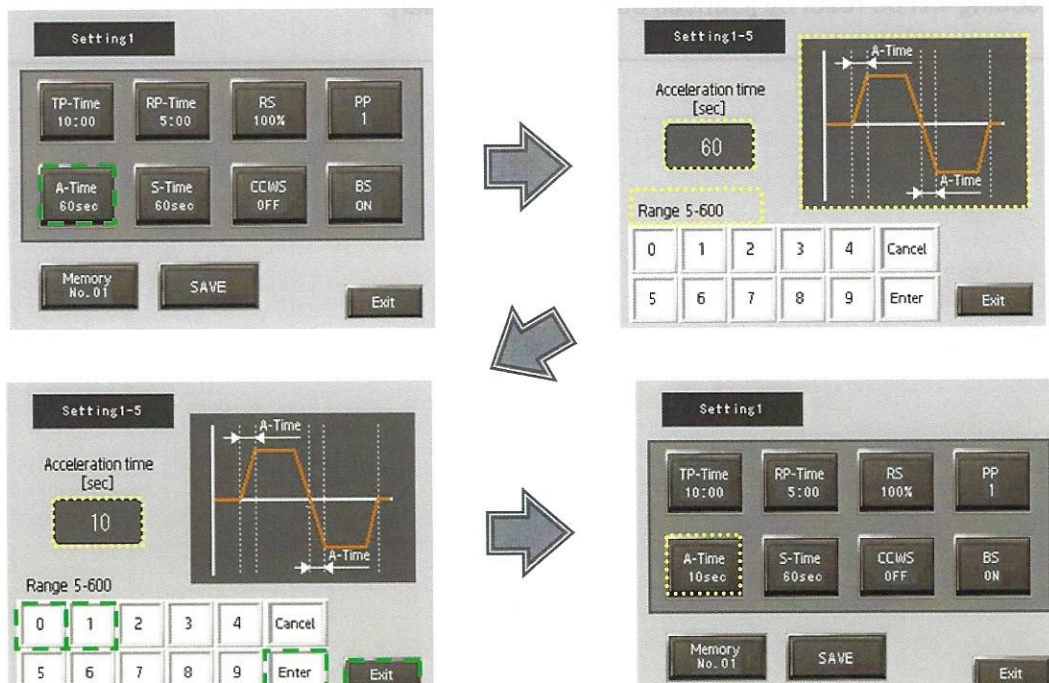

6-1-6. ST (Slowdown Time)

No.	Parameter	Description	Unit	Default	Range	Minimum unit
6	ST	Slowdown time	sec	60	5-600	1

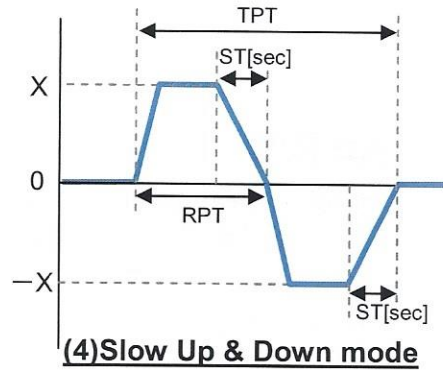
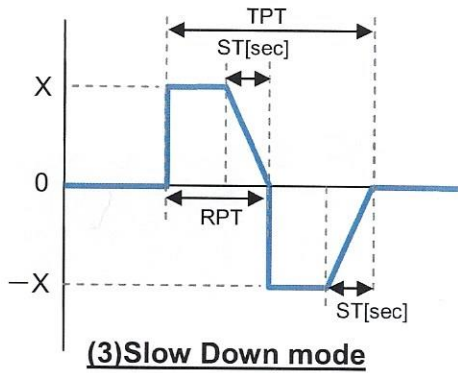

ST is time for slow down when stopping at RPT and TPT over.

Default setting value is 60 seconds and the range is 5 to 600 minute with minimum unit 1 second.

Valid only for PP (3) Slow down mode or (4) Slow Up & Down mode.

< How to edit >

- Push down [Setting] button for 0.5 second to move onto [Setting 1] window from Main window.
- Push [ST] (Slowdown time) button to go to [Setting 1-6] window.

Chart of ST is shown at right upper corner, Setting Value at present at left side on the window.

Range is shown below the setting value.

- Push [2], [0], [Enter] button on key board when you edit ST from 60 to 20.

Push [Exit] button to go back to [Setting 1] window to double check the setting is surely changed.

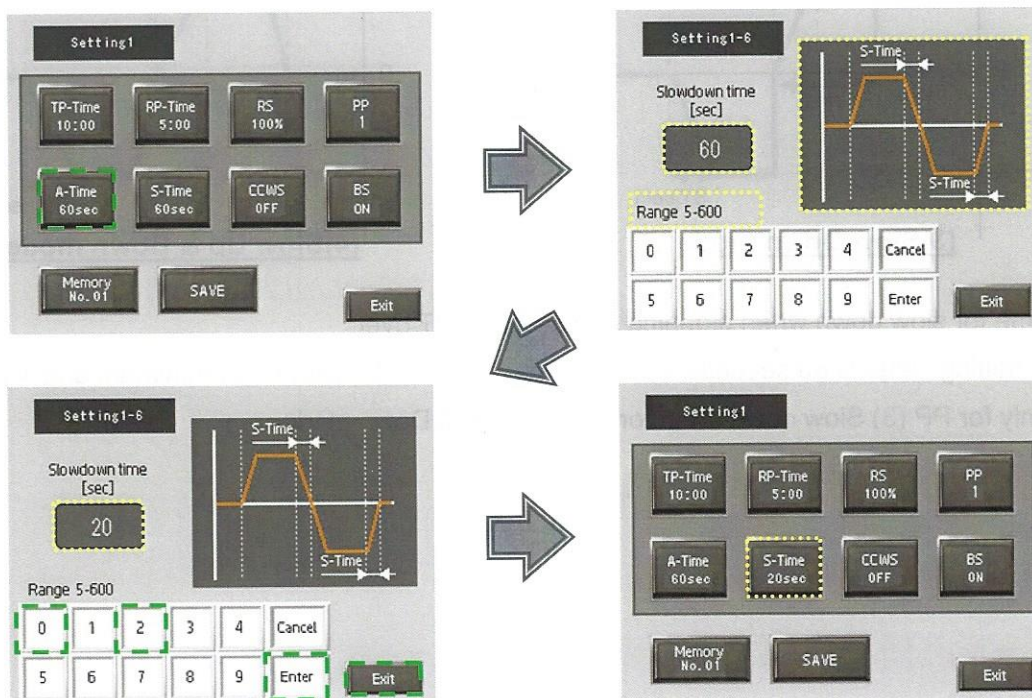

6-1-7. CCWS (Counter Clockwise Setting)

No.	Parameter	Description	Unit	Default	Range	Minimum unit
7	CCWS	Counter clockwise setting ON / OFF	-	OFF	ON or OFF	-

CCWS is a parameter for Counter clockwise setting ON or OFF.

Default setting is OFF.

< How to edit >

- Push down [Setting] button for 0.5 second to move onto [Setting 1] window from Main window.
- Push [CCWS] (Counter clockwise setting) button to go to [Setting 1-7] window.

Present Setting Value is shown at left side on the window.

- Push [ON] button on the window when you want to activate it.

Push [Exit] button to go back to [Setting 1] window to double check the setting is surely changed.

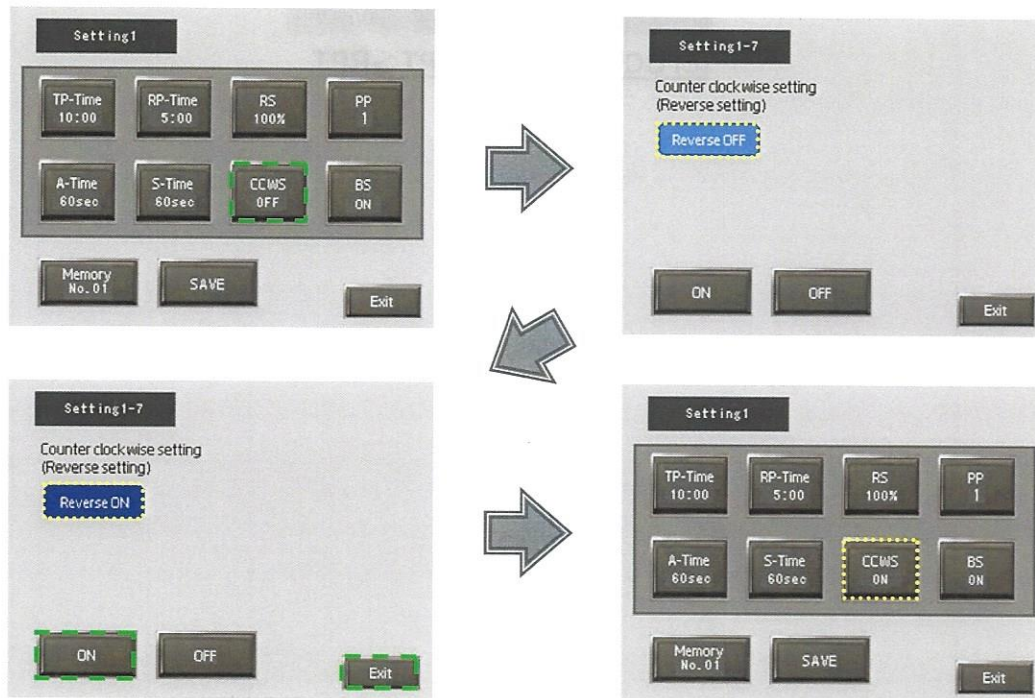

* Main window will be changed when CCWS activated as below;

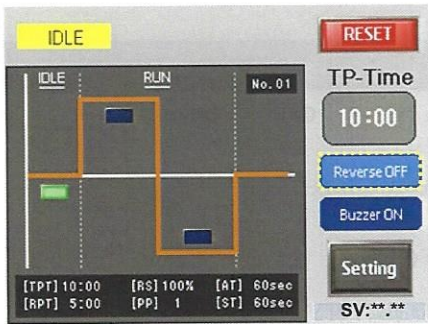

(a) CCWS OFF

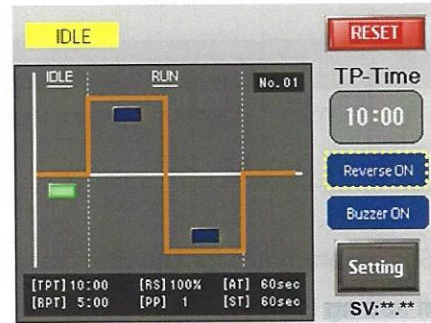

(b) CCWS OFF

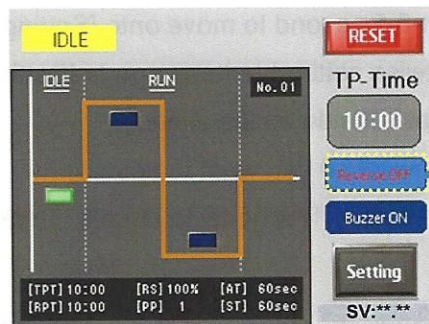

(c) CCWS ON and $TPT \leq RPT$

6-1-8. BS (Buzzer Setting)

No.	Parameter	Description	Unit	Default	Range	Minimum unit
8	BS	Buzzer Setting ON / OFF	-	ON	ON or OFF	-

BS is a parameter for Buzzer setting of signal light ON or OFF.

Default setting is OFF.

* The buzzer cannot be canceled once it activates.

* The buzzer on LCD cannot be canceled.

< How to edit >

- Push down [Setting] button for 0.5 second to move onto [Setting 1] window from Main window.
- Push [BS] (Buzzer setting) button to go to [Setting 1-8] window.

Present Setting Value is shown at left side on the window.

- Push [OFF] button on the window when you want to set it OFF.

Push [Exit] button to go back to [Setting 1] window to double check the setting is surely changed.

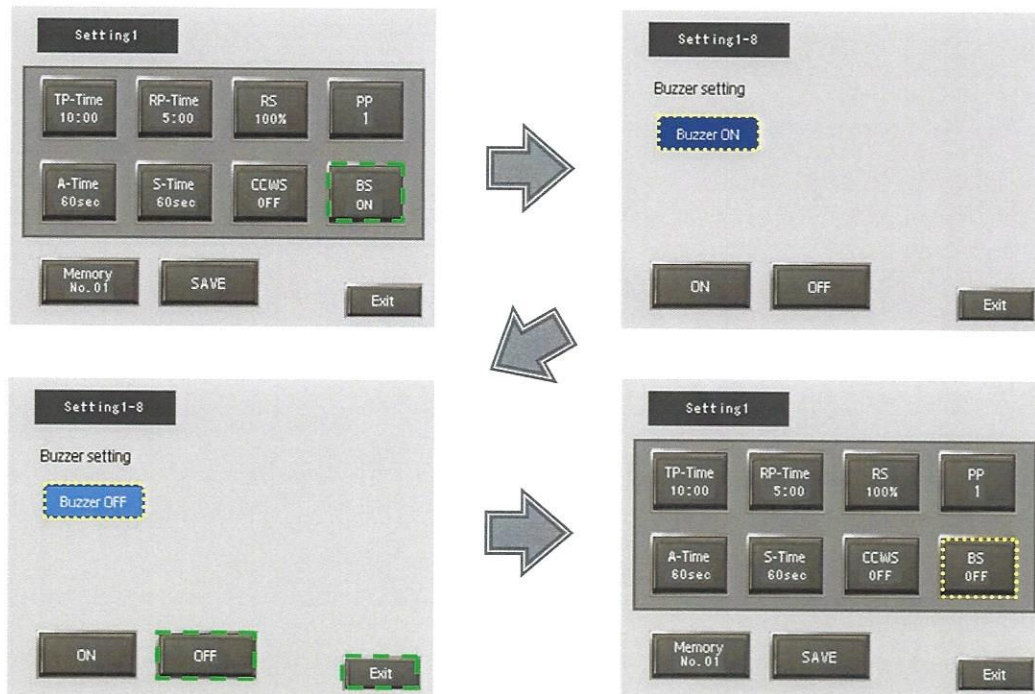

* Main window will be changed when BS activated as below;

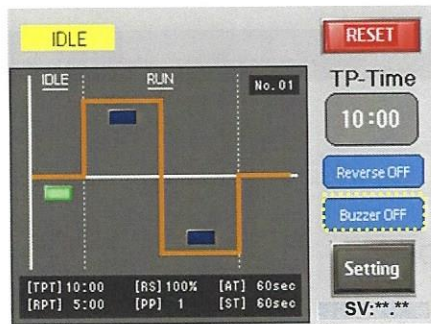

(a) BS OFF

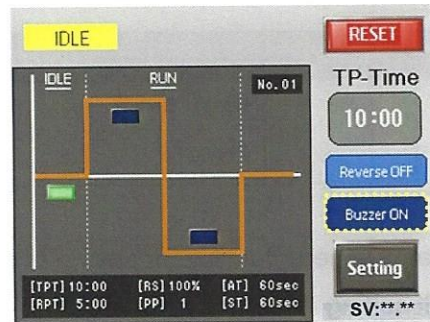

(b) BS ON

6-1-9. Memory (Memory number Setting)

No.	Parameter	Description	Unit	Default	Range	Minimum unit
9	Memory	Memory number setting	-	1	1-10	1

Memory stores 8 parameters No.1(TPT) - No.8(BS) which have been described as above.
EM-7 has 10 memories and default memory is No.1.

< How to edit >

1) Changing memory number

- Push down [Setting] button for 0.5 second to move onto [Setting 1] window from Main window.
- Push [Memory NO.01] button to go to [Setting 1-9] window.

Present Setting Value is shown at left side on the window.

- Push [5], [Enter] button on key board when you change memory number from 1 to 5.

Push [Exit] button to go back to [Setting 1] window to double check the setting is surely changed.

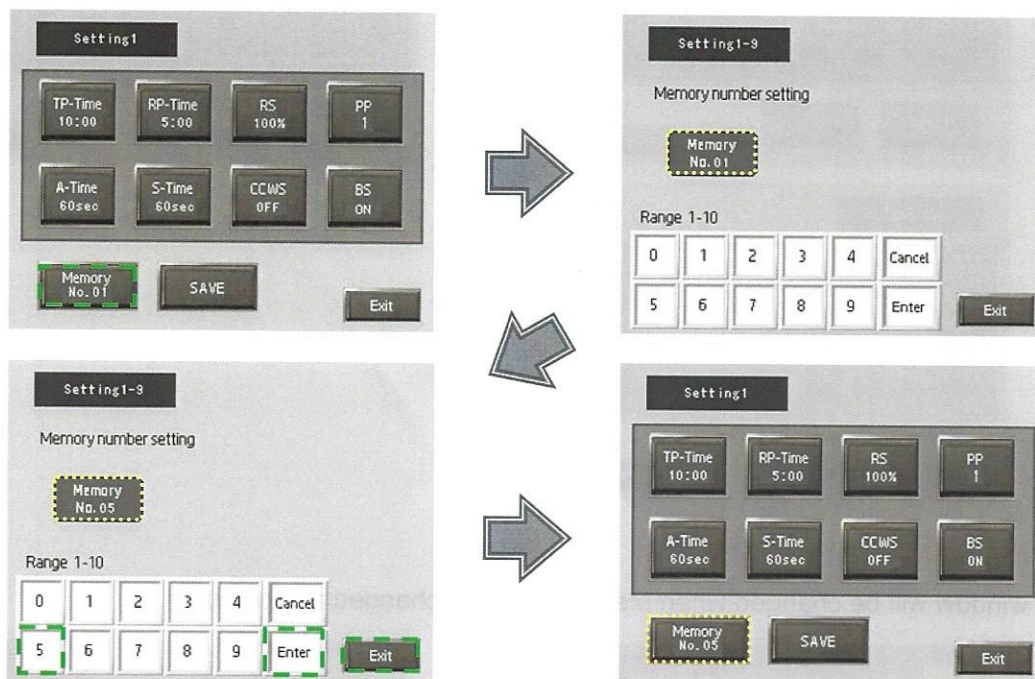

2) Saving parameters in new memory

- Edit parameters TPT - BS
- Push down [SAVE] button for 2 seconds at [Setting 1] window until buzzer beeps.
- Call other Memory No., Come back to memory No.5 again to double check the parameter is surely saved.

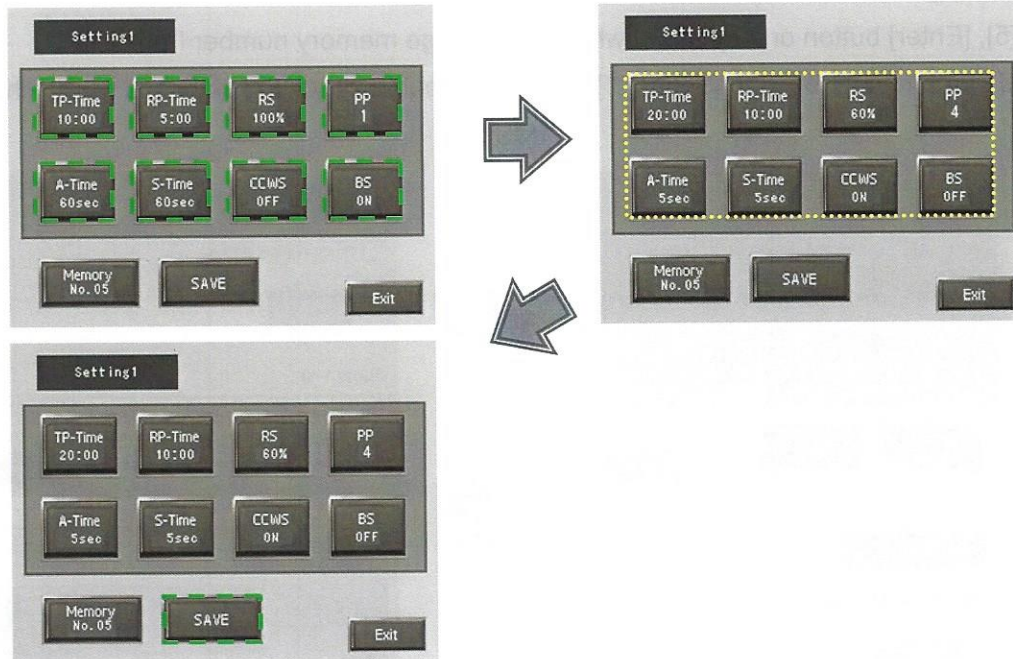

* Main window will be changed when Memory number changed as below;

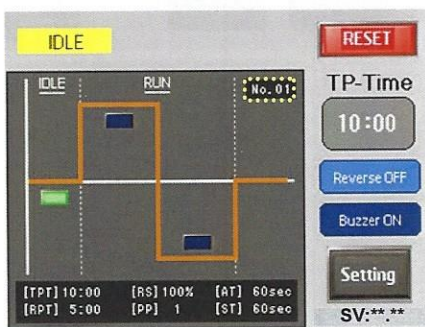

(a) MemoryNo.1

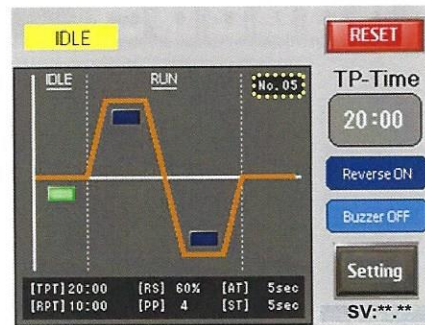

(b) MemoryNo.5

6-2. ADDITIONAL INFORMATION

Some information for better polishing result is described here in this chapter.

1) General conditions

Check those conditions at the beginning;

Condition	Descriptions
Workpieces	Material, amount, shape
Media	Material, amount, shape, dirty or not
Water	Water quality, amount, temperature (low temp recommended)
compound	Compositions , amount
Parameter settings	TPT (Total process time), RPT (Reverse process time), RS (Rotation speed setting), PP (Process pattern), AT (Acceleration time), ST (Slowdown time), CCWS (Counter clockwise setting)
Working conditions	Electricity, Temperature, Humidity

First of all, try to keep red marked conditions above being fulfilled.

Polishing media must be from Yasui, maintained clean after polishing, on progress if necessary.

Water also must be kept clean which means to be exchanged every time.

Cold water like below 20 degrees Celsius brings better result.

Strongly recommended to use polishing compound from Yasui.

Good working condition with stabilized electric power, room temperature 20 c, humidity 50%.

It is very important to get those conditions for stable polishing results.

2) Observation of work pieces and parameter setting

Next try to find and set polishing parameters depending on work pieces' shape and amount.

You can refer the parameters below if you have no idea so that you will be able to edit them based on it.

< Condition >

Work pieces: 2kg

Media: 2.0kg

Water: 6L

Compound: 30cc

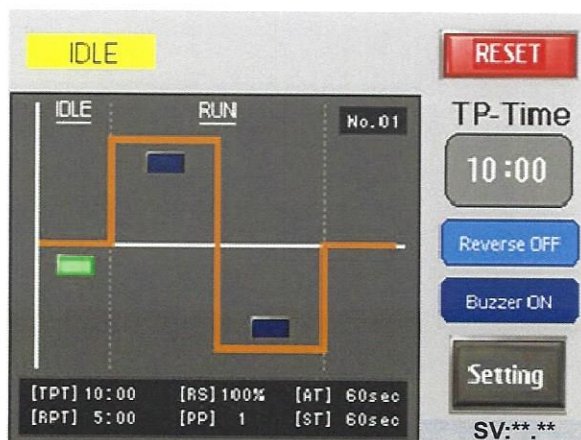

3) RS rotation speed check

You can check rotation speed by following process before editing parameter.

< How to check >

- Call Process Pattern (1) Step mode and set TPT and RPT timer more than 5 minutes.
- Push down [Setting] button for 0.5 second to move onto [Setting 1] window from Main window.
- Push [RS] (Rotation speed setting) button to go to [Setting 1-3] window.
- Push [START] button. The status changes to [RUN] and you can try all of speeds on the window.
- Push [60], [Enter] button for 60% speed for example.
- Push [Exit] button to go back to Main window, push [RESET] button for 0.5 seconds to finish.

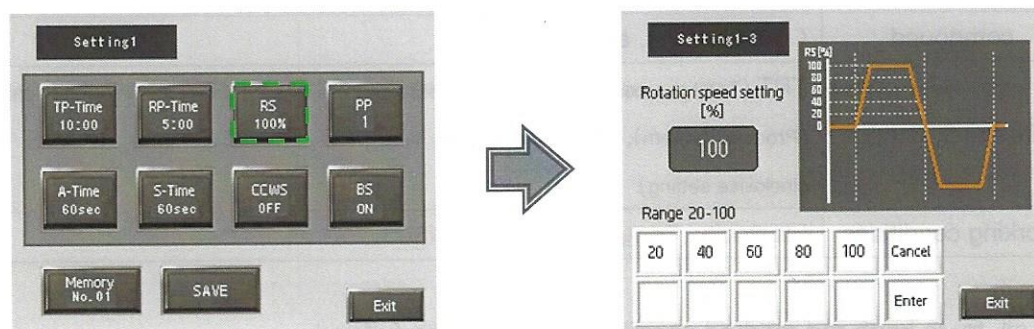

* Do not try this without polishing media and water in container.

7. ERROR MESSAGES

You can refer the following error code list when you have an error at status IDLE (Standby).

Remove the cause and push down [RESET] button for 0.5 second to cancel the error.

Code	Incident	Description
E010	Input power anomaly	Over 3P 230V±10% (Max500V) voltage supplied. Power supply is automatically cut off, thus nothing displayed on operation panel. Check indicator on voltage monitoring relay located in control cabinet.
E020	Inverter anomaly	Inverter anomaly detected, operation suspended.
E021	Inverter overload	Overload on inverter detected, operation suspended.
E030	Temperature anomaly	Abnormally high temperature over 120 degrees Celsius detected inside of machine body, Operation suspended until cooled down to lower than 80 degrees Celsius.
W010	Overheat	Warning indicated on LCD when temperature inside of machine body got over 80 degrees Celsius. Only warning and no suspension on operation.

Input power anomaly(E010)

< Phenomenon >

No reaction by breaker ON and [READY] pushed down.

< Cause >

Electric power is out of range, 3P 230V±10%.

Cables are connected on incorrect phases.

< Remedy >

Check indicator on voltage monitoring relay located in control cabinet.

You can refer chapter 3-4 for the location.

Check chart below to find the cause and solve the problem.

Indicator RY_LED is normally ON, ALM_LED is OFF.

Article	RY_LED	ALM_LED
Over voltage	OFF	ON
Insufficient voltage	OFF	ON
Opposite phase	OFF	Blinking
Normal phase	ON	OFF

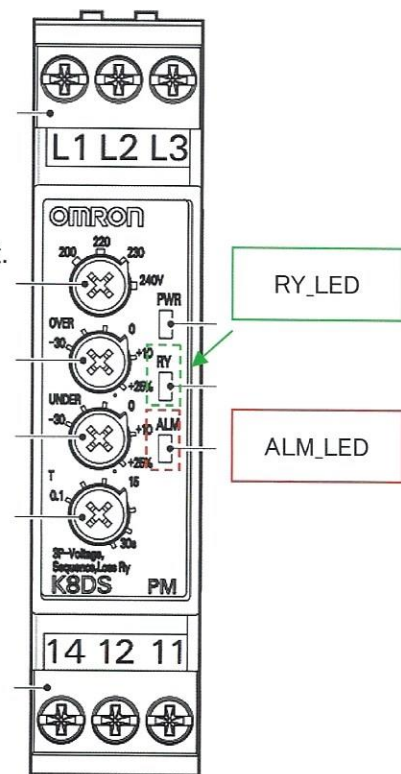

Inverter defective (E020)

< Phenomenon >

Error [E020] is displayed on LCD. Operation is suspended forcibly.

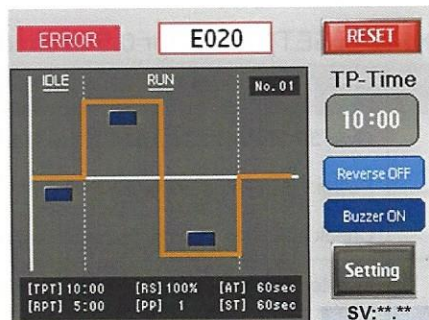

< Cause >

Some error(s) occurred on inverter.

<Remedy>

Push down [RESET] button for 0.5 second to cancel and erase the error message.

If the status is IDLE (Pause), push [RESET] button again for 0.5 second to reset the status to IDLE (Standby).

Turn breaker switch OFF, wait for 1 minute to turn ON, push [READY] button.

Check the amount of contents in container is correct, push [START] button to start operation.

Contact us when the problem still remains even if there is nothing wrong on power supply and surroundings.

Overload on inverter (E021)

< Phenomenon >

Error [E021] is displayed on LCD. Operation is suspended forcibly.

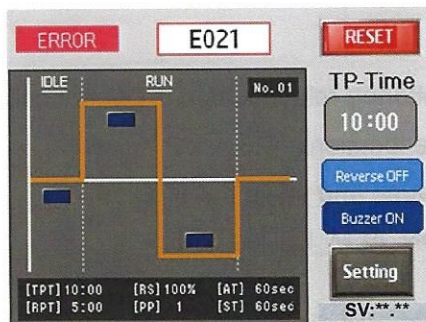

< Cause >

Something wrong happening on load of object

< Remedy >

Same process has to be done as of error E020.

Temperature anomaly (E030)

< Phenomenon >

Error [E030] is displayed on LCD. Operation is suspended forcibly.

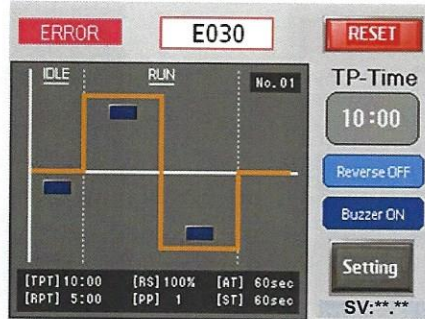

< Cause >

Abnormally high temperature over 120 degrees Celsius detected inside of machine body.

<Remedy>

Push [RESET] button to cancel and erase the error message.

If the status is IDLE (Pause), push [RESET] button again for 0.5 second to reset the status to IDLE (Standby).

Leave this product to cool down for approx. 1 hour.

Turn OFF and Reboot after 1 minute, push [READY] button.

Check the amount of contents in container is correct, push [START] button to start operation.

Contact us when the problem still remains even if there is nothing wrong on power supply and surroundings.

Overheat (W010)

< Phenomenon >

Error [W010] is displayed on LCD. Operation is suspended forcibly.



< Cause >

Very high temperature over 80 degrees Celsius detected inside of machine body.

<Remedy>

Only warning and no suspension on operation.

* EMERGENCY STOP button

Push this button to stop all of the functions in case of emergency.

After removing the problem, turn EMERGENCY STOP button clockwise, push [READY] button.

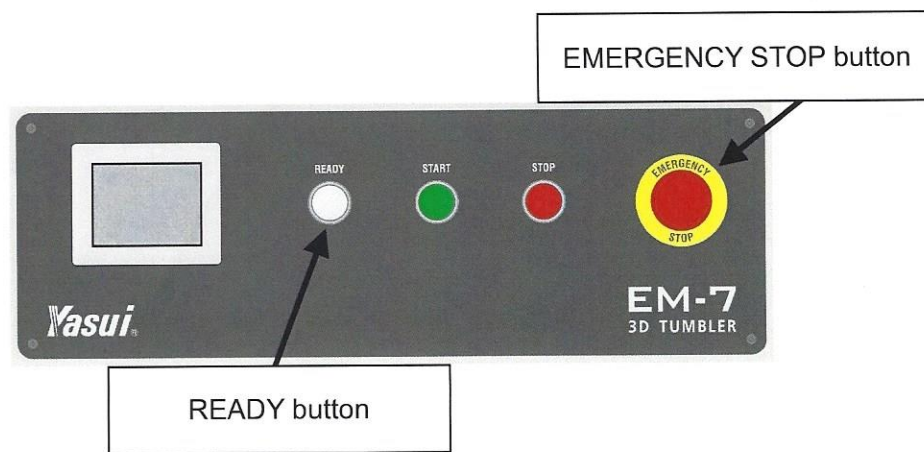

8. MAINTENANCE

Routine maintenance is necessary for long use with good condition as following step.
Do not forget to turn off EM-7 breaker switch as well as breaker switch on wall.

MACHINE

1) Exterior

Keep operation panel and table dry always.

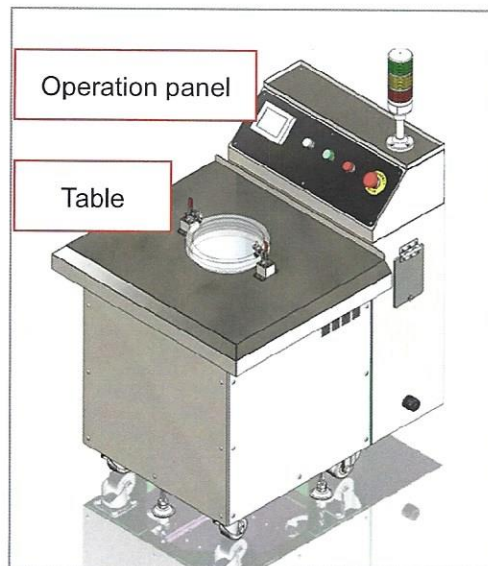

2) Air inlet / Exhaust port

There are air inlets on the bottom of machine body, Exhaust port on both side of body and backside.

⚠ Turn Off breaker and Remove dust around them.

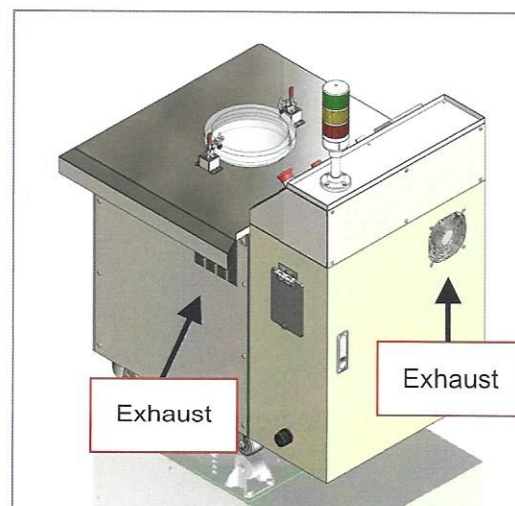
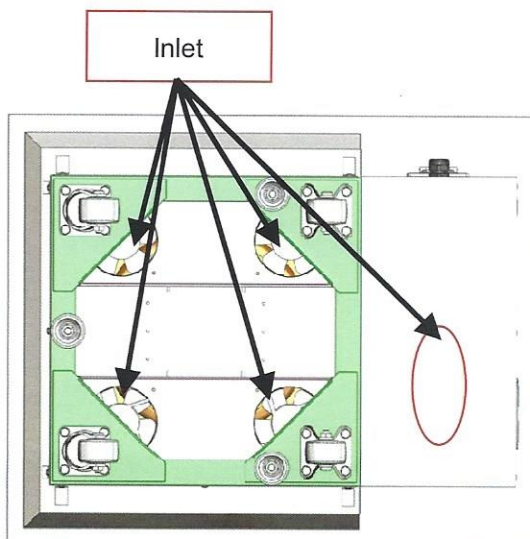

ACCESSORY

1) Polishing media

You can start using polishing media without any treatment beforehand.

Polishing media will catch dirt from workpieces and get coated with grayish color.

Dirty media affects workpieces and make them black if not cleaned well.

Try to maintain media clean by compound or neutral detergent.

Pay attention when cleaning media as it is very fine wire.

* Compound water solution is disposable like a kitchen detergent.

Do not use any polishing media which is not from YASUI as we do not guarantee the polishing result.

Polishing media will not be used forever.

Replace old media if you notice the polishing effect is not strong enough anymore.



9. CONSUMABLES

Articles		Code number	Remarks
Container		18601001	For EM-7 Lot A only
Media	φ0.3×3mm	19029820	
	φ0.3×5mm	19030000	
	φ0.5×3mm	19030230	
	φ0.5×5mm	19030200	
Compound		19340000	All in one type

10. WORDS AND TERMS

■ Container

Exclusive container for polishing on EM-7.

There are 4 gaps on its bottom to prevent rotating together with content.



■ Compound

Dilute with water when polishing to get special effect on polishing.

10-30cc is for a single process.

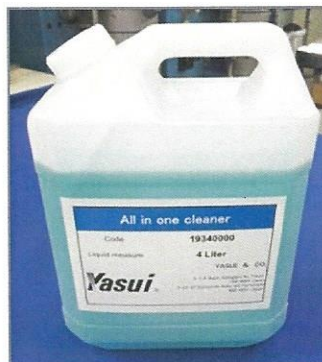

■ Polishing media

Special stainless steel pins for polishing with special treatment on edges.



■ Workpieces

Workpieces as of non-magnetic metal parts and plastic products to be polished on EM-7.

We often polish whole casting trees and cut casting pieces.

Following pictures are workpieces before polishing.



■ 3D TUMBLER / EM-7

3D TUMBLER is our original electric magnetic polisher.

EM-7 is model name.

Alternating current generates three dimensional magnetic field which is completely different from ordinary magnetic polishing machine.



11. DIAGRAM

WIRING DIAGRAM

