

Indutherm VC 680V Full Automatic Casting Machine

Product Manual



Contents

Contents	3
1 General information	1-1
1.1 Scope of delivery and responsibilities	1-1
1.2 Liability, warranty and guarantee	1-1
1.3 Responsibility of operating company	1-2
1.4 EC-conformity	1-2
1.5 Observation of the product	1-2
2 Safety	2-1
2.1 Intended use	2-1
2.2 Demands on staff, duty for utmost care	2-2
2.3 Protective measures	2-2
2.3.1 Concept of safety	2-3
2.3.2 Protective gear	2-3
2.3.3 Safety equipment	2-3
2.3.4 Main switch with emergency stop function	2-4
2.3.5 Safety markings on the unit	2-4
2.4 Safety marking	2-5
2.5 Safety advices	2-6
2.6 Residual risks	2-10
2.7 Behaviour in an emergency	2-10
3 Technical data	3-1
4 Description of the system	4-1
4.1 Components of the system	4-1
4.2 Schematic representation	4-2
4.3 Backside connections	4-3
4.4 Setup of the crucible chamber	4-4
4.5 Feeder system	4-5
4.6 Additional gas tank	4-6
4.7 Special options	4-7
4.7.1 Centre- and wall measurement (Dual measurement)	4-7
4.7.2 Granulation tank	4-8
4.7.3 Hinged window	4-9
4.7.4 Inductor 110 mm	4-9
4.7.5 Flask height with 260 mm (10") with 'special-pin' 711143214-10	
5 Transport	5-1

6	Mounting and commissioning	6-1
6.1	Safety advices for mounting	6-1
6.2	Mounting process.....	6-1
6.3	Apply supply connections.....	6-2
6.3.1	Power supply	6-2
6.3.2	Cooling water	6-2
6.3.3	Compressed air	6-3
6.3.4	Protective gas	6-3
6.3.5	Vacuum.....	6-3
6.3.6	Gas outlet	6-4
6.3.7	Vacuumpump (mains socket 16 A).....	6-4
6.3.8	RS232.....	6-4
6.3.9	USB socket (universal serial bus).....	6-5
6.3.10	LAN-socket (Local Area Network)	6-5
6.3.11	Internal modem	6-5
7	Operation.....	7-1
7.1	Safety advices for operation	7-1
7.2	Changing casting parts	7-2
7.2.1	Removal.....	7-2
7.2.2	Mounting	7-2
7.3	Front panel.....	7-3
7.3.1	LCD screen after mains switch on	7-3
7.3.2	Program change page 1	7-4
7.3.3	Program change page 2.....	7-6
7.3.4	Predefined casting programs	7-7
7.3.5	System parameter	7-8
7.3.6	State Level	7-9
7.3.7	VC680V Front panel below display	7-10
7.4	Protective Gas flow	7-11
7.5	Casting.....	7-11
7.6	Possible causes for dissatisfying casting results	7-14
7.7	Flask structure	7-15
7.8	Granulating	7-16
7.9	Casting reports.....	7-19
7.10	Error diagnosis	7-20
7.11	Troubleshooting	7-20
7.12	Diagram casting flasks without flange	7-21
7.13	Diagram casting flasks with flange	7-21
7.14	Service.....	7-21
8	Maintenance	8-1
8.1	Safety advices for repair and maintenance	8-1
8.2	Maintenance schedule	8-3

8.3 Repair 8-5

9 Dismantling and cleaning up 9-1

10 Annexe..... 10-1

10.1 List of figures..... 10-1

10.2 CE-Declaration of conformity 10-3

10.3 Test result chart 10-5

10.4 Connection diagrams 10-6

10.5 Assembly drawing VC680V 10-9



10.6 Consumable and spare parts list 10-10

10.7 Error and warning messages 10-12

1 General information

1.1 Scope of delivery and responsibilities

The vacuum pressure casting machine VC680V is delivered complete. Please check the delivery immediately after receiving the shipment if there are something missing or possible transport damages. Please tell the faults the shipping agency and your dealer.

	<p>Information!</p> <p>There are two tilt sensors. One is on the transport box. Check the outdoor sensor as long as the transport company is there. A sensor is in the machine.</p>
<p>Figure 1: Sensor #84400010</p>  <p>Tilting Sensor to show transport damages</p>	<p>If the machine was tilted.</p> 

1.2 Liability, warranty and guarantee

The company *INDUTHERM Erwärmungsanlagen GmbH* takes liability, warranty and guarantee according to the legal regulations.

The vacuum pressure casting machine is built to be state-of-the-art and in compliance with the accepted safety regulations. Nevertheless, can improper installation and non-intended using can lead to danger and damages.

INDUTHERM Erwärmungsanlagen GmbH doesn't take liability for damage caused by untrained personnel operating the machine.

For damages because of demonstrably misusing of machine or because of abnormal behaviour no liability will be taken by *INDUTHERM Erwärmungsanlagen GmbH!*

INDUTHERM Erwärmungsanlagen GmbH doesn't take liability for damages caused by faulty protection of power supply and/or wrong connection of the supplies (protective gas, water, compressed air).

There is no guarantee for consumables by *INDUTHERM Erwärmungsanlagen GmbH*.

Company *INDUTHERM Erwärmungsanlagen GmbH* cannot and will not take responsibility for all consequential damages caused by above mentioned circumstances.

This operating manual is of the technical state at printing date. All rights reserved regarding technical changings and different equipment.

Damages caused by disregard, wrong interpretation and non-compliance with specifications in this manual will lead to expiration of guarantee for this system.

1.3 Responsibility of operating company

The operator has to meet with national accident preventing regulations and technical regulations.

The operating company is allowed to let operate the machine by trained and trustworthy personnel only.

The operating company has to make sure that the system is supervised by staffs that are trained at this device.

The operating manual must be kept right next to the system.

The operating company has to ensure that the operating personnel has **read and understood** the manual before they are going to use the machine.

The operating company has to ensure that unauthorized person has no access to the system.

Maintenance actions should only be done by authorized personnel or by service technicians from Indutherm.

1.4 EC-conformity

A declaration of European Community conformity is attached to this manual.

1.5 Observation of the product

The management will provide you with a secure machine at state-of-the-art.

Please let us know immediately if there are:

- failures at safety measurement devices,
- failures during production,
- modified parameter settings,
- difficulties in using the system,
- accidents or near accidents and
- remarks for improvement of the manual.

2 Safety

2.1 Intended use

Operational safety of the vacuum pressure casting machine is only guaranteed at intended use.

The casting machine serves exclusively for melting, pouring and vacuum casting of commercially available precious metals and of copper- or aluminium-alloys. The specified temperature ranges must be complied with.

Every other use of the overall plant or parts is considered as not intended.

Unauthorized modifications of the plant are prohibited because of reasons for safety! CE declaration of conformity expires with modification.

Intended use includes reading, knowing and obeying the operating instructions. That also contains observing of servicing and maintenance regulations.

Set up, operation and maintenance is only allowed to be carried out by trained qualified personal that has read and understood all documents.

The plant may affiliate only to the specified media. Supply voltage and input respectively output pressure have to be observed to the given device labelling accordingly.

The machine has been developed for use in enclosed spaces and for the above mentioned application.

Only original INDUTHERM consumables and spare parts are admitted for operation.

It is not allowed to change or vary the system in any way. Technical changes need explicit written approval of *INDUTHERM Erwärmungsanlagen GmbH*.

The vacuum pressure casting machine is not intended to melt medically or biologically contaminated components.

The casting machine must not be placed in areas with explosive atmospheres.

The vacuum pressure casting machine is not intended to melt medically or biologically contaminated components.

Predictable abuse:

- Warming of human body parts on hot surfaces.
- Heating and casting of others then the mentioned metals.

2.2 Demands on staff, duty for utmost care

Work on and with the machine is allowed to be accomplished by reliable, trained and instructed staff only. Responsibilities for the separate sections have to be regulated clearly, which include operation, preparation, service and repair.

Only authorized personnel should act at the system.

The machine should never be operated by personnel under influence of reflex diminishing medicine or people not able to work because of illness or disorder.

Running of the system has to be always supervised by trained staff.

Personnel which have to be trained und introduced to this job or within the course of vocational training may work only under permanent observation of a person experienced with the machine.

Work on the electrical equipment is only allowed for workers skilled in the field of electricity.

The instruction manual has to be freely disposable at the location of the system. The employees have to know the storage place.

Every person working at the system has to read and apply the instruction manual especially the safety advices. The personnel have to read and understand the chapters referring to safety aspects for the particularly components of the machine. Please read before beginning the work.

Please control the personnel for paying attention to all facts of safety and danger prevention.

2.3 Protective measures

This operator's guide contains all important advices to operate the system secure.

Basic prerequisite for safe dealing and trouble-free running of this system is the knowledge of fundamental safety advices and industrial safety rules.

In commercial facilities you have to regard the accident prevention regulations of the professional association for electrical systems and tools.

During operation of the system gases / vapours may escape. This depends on the application, the consumable parts used, and the metals processed. The plant operator must provide a suitable exhaust system on site according to the current standards and laws appropriate.

The lightning protection and the measures for overvoltage protection must be ensured on site.

The internal regulations of industrial safety are to be observed.

2.3.1 Concept of safety

Objective is the safety:

- of the staff against injuries;
- of the system against damage or standstill and
- of the environment against pollution.

The list of actions taken:

- deployment of protective equipment like covers and main-switch with emergency stop function,
- safety switch that is used to ensure that the plant can be operated only with the swivelled vacuum pressure casting tank;
- water-cooled inductor housing,
- duty of wearing personal protective equipment (PPE),
- affix safety markings on the installation,
- create safety advices in the manual.

2.3.2 Protective gear

Protective gear (PPE) includes:

- heat-resistant clothes,
- heat-resistant, closed shoes,
- heat-resistant protective gauntlets protecting artery and
- face guard.



Caution!

Wear always for every process step the right protective gear.

2.3.3 Safety equipment

The safety of the machine is only guaranteed if all safety equipment is proper installed and working proper. Don't use the system without the safety equipment!

Disassembling safety equipment is only allowed with locked main-switch. Install every part of the safety equipment after repair. Perfect function has to be checked.



Caution!

Safety equipment protect from unintentional access of the staff to danger spots. They prevent possible injuries. Never manipulate the safety devices!

2.3.4 Main switch with emergency stop function

It is allowed to start the machine or operation only with proper emergency stop function.







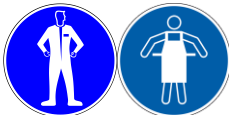

	<p>Caution!</p> <p>With the emergency stop function you can stop the machine in critical moments of health hazard. You help to diminish potential consequences of injury.</p>
-----------------------------------------------------------------------------------	--------------------------------------------------------------------------------------------------------------------------------------------------------------------------------------

- > Don't manipulate the emergency stop equipment.
- > Don't obstruct the way to the emergency stop equipment.

2.3.5 Safety markings on the unit

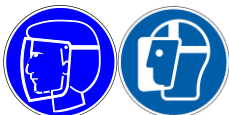
A necessary condition for safe dealing with and undisturbed running of the machine is the knowledge of safety instructions and industrial safety regulations.

On the front of the machine casing the following safety markings are attached.

safety marking	meaning	safety marking	meaning
	warning of dangerous electrical voltages		wear heat resistant safety clothing
	warning on hot surfaces		wear heat resistant protective gauntlet gloves protecting artery
	forbidden for persons with pacemaker		wear face guard
	Warning of hand injuries.		wear protective shoes
			read manual

	<p>Advice</p> <p>Keep the safety markings always clean. Replace the markings if they aren't recognizable. Observe the warnings and commands. Don't expose yourself careless to dangerous situations.</p>
-------------------------------------------------------------------------------------	-----------------------------------------------------------------------------------------------------------------------------------------------------------------------------------------------------------------

2.4 Safety marking

The following signal words are used in this document, which are associated with safety markings for presentation of possible dangerous situations.



Danger!

Death, serious body injury or substantial property damage **will result** if proper precautions are not taken.



Warning!

Death, serious injury or substantial property damage **can result**, if proper precautions are not taken.



Careful!

Minor personal injury can result if proper precautions are not taken.



Attention!

Property damage can result, if proper precautions are not taken.



Information/advice

Here you get information and advices to carry out the following activities effective and safe.

2.5 Safety advices

Check always the condition of the system before you switch on the system. Examine the supply pipes and insulations if there are leaks and damages. Operate the system only if it is in proper and faultless shape.

Operate the system never:

- if there are malfunctions,
- if it is showing damage or
- after heavy transportation stress.

The system has to be constantly controlled when running to be able to recognize and avoid dangerous situations. The system may not run if it is unsupervised.

Do never change, remove or close the safety valves inside the machine.



Danger!

Danger to life because of strong electromagnetic fields (induction). For persons with pacemaker it is not allowed to approach or to be near to the machine.



Danger!

Danger to life is caused also by the fact that very hot and liquid metals solidify in cold liquids. During this it can emerge physical and chemical reaction, which is to be evaluated by the operator. For example, can with aluminium happen an explosion of hydrogen gas during hydrolysis.



Warning!

Risk of burning on hot surfaces and hot metal (until ~ 1700 °C). Wear always personal protective equipment when you work with the machine.

Utmost caution during using graphite crucibles and graphite moulds. The heat of these parts is only visible when the temperatures are over 500 °C.



**Warning!**

Maintenance and servicing of the machine only when the system is disconnected from the mains supply (Pull out mains plug).

**Advice!**

Don't disconnect mains plug while machine is running or in standby. Switch off for pulling out or putting in mains plug.

**Danger!**

Risk of burns. If metal is melted without the supply of protective gas, can cause a flash fire or explosion when opening the lid can result. Melt at temperatures above 500 °C always with protective gas. Use as a protective gas exclusively argon or nitrogen.

**Danger!**

Danger because of touching parts conducting voltage. Work on the electrical equipment is only allowed for authorized qualified staff.

Access to the electrical distribution box is only allowed for authorized qualified staff with tool.

Work on the electrical equipment is only allowed when the system is disconnected from power supply (pull out power plug).

- The capacitors can retain their charge even after de-activation of the system.
- Keep the housing of the vacuum pressure casting machine closed continually.
- No work must be carried out on parts conducting high voltage.
- Remove loose connections. Replace immediately damaged scorched or slightly burned cables. Perform work only when mains plug is pulled out.
- Cables may not wedge in or rather squeezed. Cables have to be laid in a way that they not become a tripping hazard or can be not damaged.



Danger!

Threat of health injury by escape of medias from damaged hoses.
Danger of system damages.

- Remove loose connections. Replace damaged hoses immediately. Perform work only when mains plug is pulled out.
- Hoses may not wedge in or rather squeezed. Hoses have to be laid in a way that they not become a tripping hazard or can be not damaged.

Danger!

Burning risk by leaking hot metal at protective gas/compressed air failure.

In case of protective gas failure, the sealing rod can no longer close properly. Through a check valve, the pressure is maintained in the lock cylinder.

After a protective gas/compressed air failure should be activated no pneumatic units (e.g.: cylinder).

Warning!

Risk of burns:

- burns because of squirting liquid metal,
- burns at hot surfaces (important here: new insulations).

Warning!

Danger of explosion.

Dripping liquid metal can't be excluded.



The floor beneath the system must be made of non-flammable material. As well there must not be stored inflammable materials within a radius of 5 metres.

Attention!

At crucible temperatures over 100 °C the cooling water supply must be switched on. If it is not turned on, the inductor will be destroyed. If cooling water supply fails, the heating system immediately is turned off. Inspect the system for damage before putting back into operation again.

Warning!

Burning hazard because of leaking molten metal.

The system must not be operated without a sealing rod for security reasons.

The tip of the sealing rod must stay in the centre of the pouring hole even when sealing-rod is open.

With built-in and closed sealing rod the according cylinder must have a gap to the lower end stop otherwise the pouring hole is no longer properly sealed.

Danger!

Lethal injuries happen because of false transport by forklift truck.

- Pay attention to the right attachment of the means of transportation, otherwise the system can fall from forklift truck. The system must be lifted from the side only, because the centre of gravity is located in front and towards the upper third of the machine.
- With too small dimensioned or forks adjusted too narrowly there is danger for the system to fall from the means of transportation.
- Wear appropriate personal protective equipment (PPE).
- Move the system only by skilled personnel qualified for transportation jobs.



For damages resulting from non-compliance of regulations in transit there is no assertion possible for warranty claims.

Warning!

Health risk because of lifting heavy weight.

Lift and transport the granulating tank only by two persons. Don't try to transport the tank by yourself. There is danger of permanently healthy damages because of physical overload.

Warning!

Risk of injury.

Make pressure leading system parts depressurized before you carry out servicing.

Warning!

Risk of slip on the floor around the installation in case someone had spilled lubricant or solvent.

Clean the floor from dirt immediately! Dispose cleaning tissues in the particular collecting boxes.

**Caution!**

Observe regulations for the mains supply written by the responsible electric power supply company, the association VDE and the local electric power station. Inappropriate connecting can lead to injuries and damages of the machine.

**Caution!**

Danger for health because of inhalation of fibre particles.

- Wear dust protection mask.
- Store crucible shield and insulation in dustproof package.
- Remove the material just before installation.
- Don't shatter crucible shield and insulation.
- Pack the materials immediately after removal dustproof and dispose the materials in this packaging.

2.6 Residual risks

risk characterisation	risk reduction
Health risk for persons with cardiac pacemaker who approach the running system.	Instruct people.
Burn injury on hot surfaces or hot molten metal.	Teach people. Wear personal protective equipment.
Danger of explosion because of dripping of liquid metal in a water filled steel tub during melting of aluminium or aluminium-alloys.	Fill the tub with sand.
Jet flame or explosion when opening the lid of the melting chamber in case of melting without protective gas.	Always melt with protective gas at temperatures above 500 °C.
Tilting and toppling of the system due to improper transportation.	Consider shipping instructions.

2.7 Behaviour in an emergency

The personnel working at the facility must be trained about the behaviour in an emergency.

All persons who are working with the machine must be informed of the possibility of rapid standstill of the plant.

3 Technical data

	VC680V
crucible volume (1)	245 cm ³ ≈ 3.5 kg/Au
flasks	Max. Ø 125 mm (5") * 240 mm (9.4") height special option 260 mm (10") height
highest working temperature (2)	Max. 1700 °C with type B thermocouple (only with high-temperature insulations)
power	12 kW
mains	3 x 400 V, 50 or 60 Hz 3 x 230 V, 50 or 60 Hz (option)
fuse protection	25 - 32 A (400 V) 32 A (230 V)
short circuit current	max 5.0 kA
thermocouple	Type K (NiCr-Ni; max. 1200 °C) or Type N (NiCrSi-NiSi; max. 1300 °C) or Type S (PtRh-Pt; max. 1500 °C)
cooling water supply	Ø 13 mm, (until 2018: Ø 8 mm) fittings with 1/4" thread 2.5 - 5 bar, min. 130 l/h, 3 to 8 °dH, PH value 7-8.5.
water output	Ø 13 mm, pressureless, maximum 70 °C (158 °F)
cooling water input temperature	15 - 25 °C / 59 – 77 °F {to prevent condensation: 20 - 25 °C / 68 – 77 °F}
recommendation for water cooler	6 kW cooling capacity (50 % of heating power of VC650V e.g. TAE evo tech 015 6.5 kW)
ambient temperature	10 - 35 °C / 50 – 95 °F
relative humidity	20 - 80 %
compressed air supply	1 x Ø 6 mm, fitting with 1/4" thread 8 bar, without oil
protective gas supply	1 x Ø 6 mm, fitting with 1/4" thread 8 bar, pure N ₂ or pure Ar, {consumption 1-3 l/min}
vacuum	1x Ø 13 mm, fitting with 1/4" thread 0 - 20 mbar absolute, min. 21 m ³ /h
overpressure in the induction chamber	max. 3 bar
weight in kg	ca. 185
IP Code International Protection Marking	IP20
dimensions in mm (Wide x Depth x Height)	600 x 880 x 1450

options	<ul style="list-style-type: none">• granulation tank (with 2nd cooling system or fresh water with Ø 8 mm input, Ø 21 mm outlet)• sinter unit• S-crucible
noise emission	75 dB (A)

(1) These are standard values which can be optionally changed.

(2) in a special configuration

4 Description of the system

4.1 Components of the system

The system consists of several modules assembled in one housing.

Inside the housing there are:

- mains cable and mains filter,
- microprocessor controlled induction generator F-type,
- middle-frequency transformer,
- oscillating circuit capacities,
- pneumatic (magnet-) valves,
- pressure regulator for pressure of the sealing rod cylinder and
- pressure regulator for protective gas.

The front plate contains:

- front panel for control of the casting process and
- printer for output of a casting report.

To the melting system belongs:

- inductor housing, water cooled with inductor, crucible, insulations, sealing rod unit, thermocouple,
- bell hinged, water-cooled and
- vacuum chamber, watercooled;
- flask lift,
- vacuum chamber lift,
- vibration unit,
- granulating tank (option) and
- sinter unit (option).

4.2 Schematic representation

Figure 2: overall view

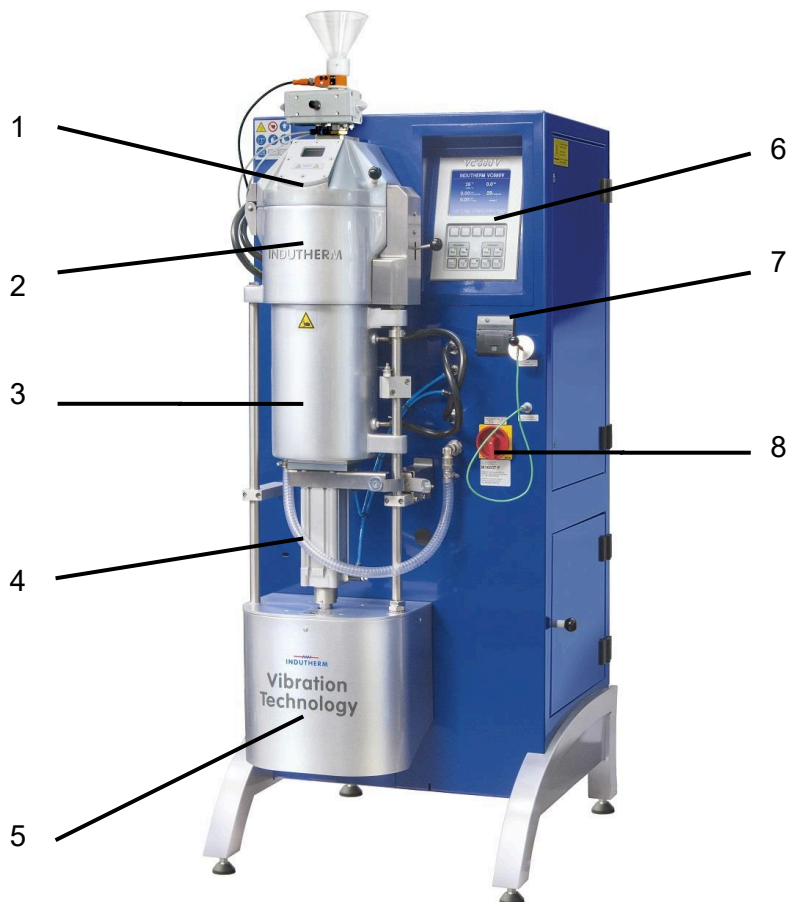

pos.	designation	Function
1	bell with window	Closing the inductor housing.
2	inductor housing (crucible chamber)	In the inductor housing are: <ul style="list-style-type: none"> • Induction coil • crucible • insulation
3	vacuum chamber	With water cooling inlet and outlet.
4	flask lift	Enables lifting of tank.
5	lift for vacuum chamber	Enables lifting of vacuum chamber.
6	front panel	Control the process of the system.
7	printer	Enables printing of casting report, list of program parameter or full system parameter overview.
8	Mains switch with emergency stop function	Switch on and off the vacuum pressure casting machine. Immediate interrupt of power in emergency.

4.3 Backside connections

Figure 3: backside of the vacuum pressure casting machine

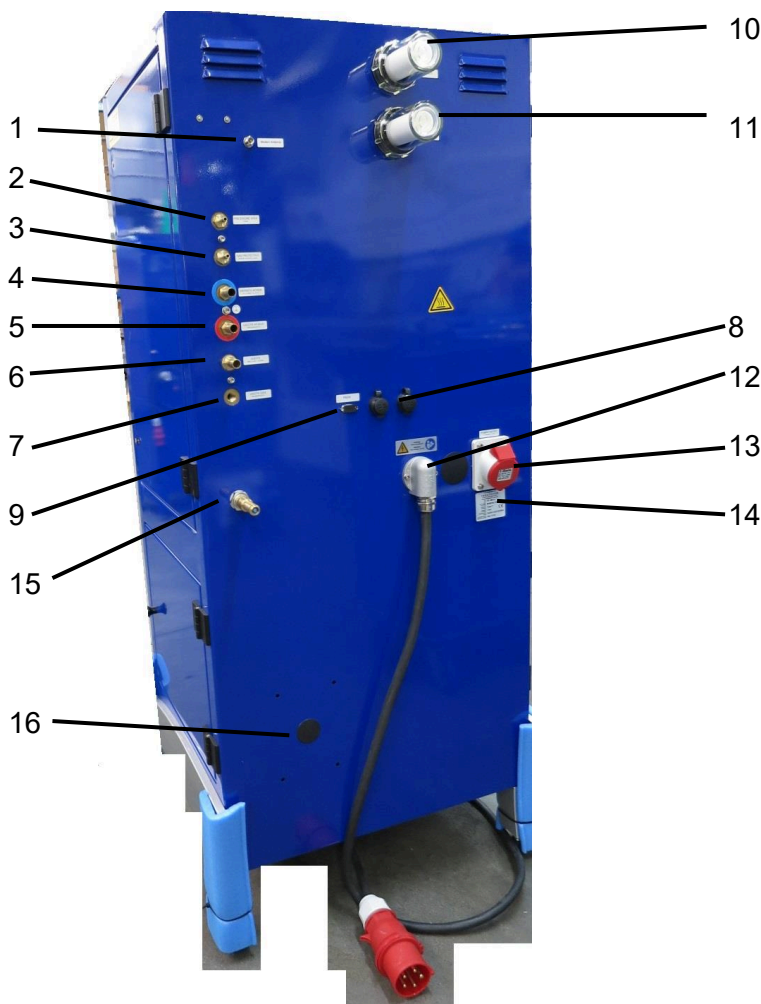

pos.	designation	Function
1	Modem	Connector for modem antenna.
2	Compressed air	Compressed air supply input.
3	Protective gas	Protective gas supply input.
4	Water Input	Cooling water supply input.
5	Water Output	Cooling water outlet.
6	Vacuum	For the hose from the external vacuum pump.
7	Gas out	Depressurization.
8	Serial Interface	Connection for PC via USB or Ethernet.
9	Serial Interface/RS232	Connection for PC over Indutherm-RS232-cable (socket actual attached to internal modem).
10	Filter crucible	Filter for vacuum in crucible area.
11	Filter flask	Filter for vacuum in the flask chamber.
12	Power supply	Power supply of the vacuum pressure casting machine.
13	Vacuum pump	Socket for plug from vacuum pump.
14	Identification plate	Important information about machine.
15	safety relief valve	Safety pressure relief valve for vacuum chamber.
16	safety relief valve	9 bar safety pressure relief valve of gas tank.

4.4 Setup of the crucible chamber

Figure 4: Setup of the crucible chamber

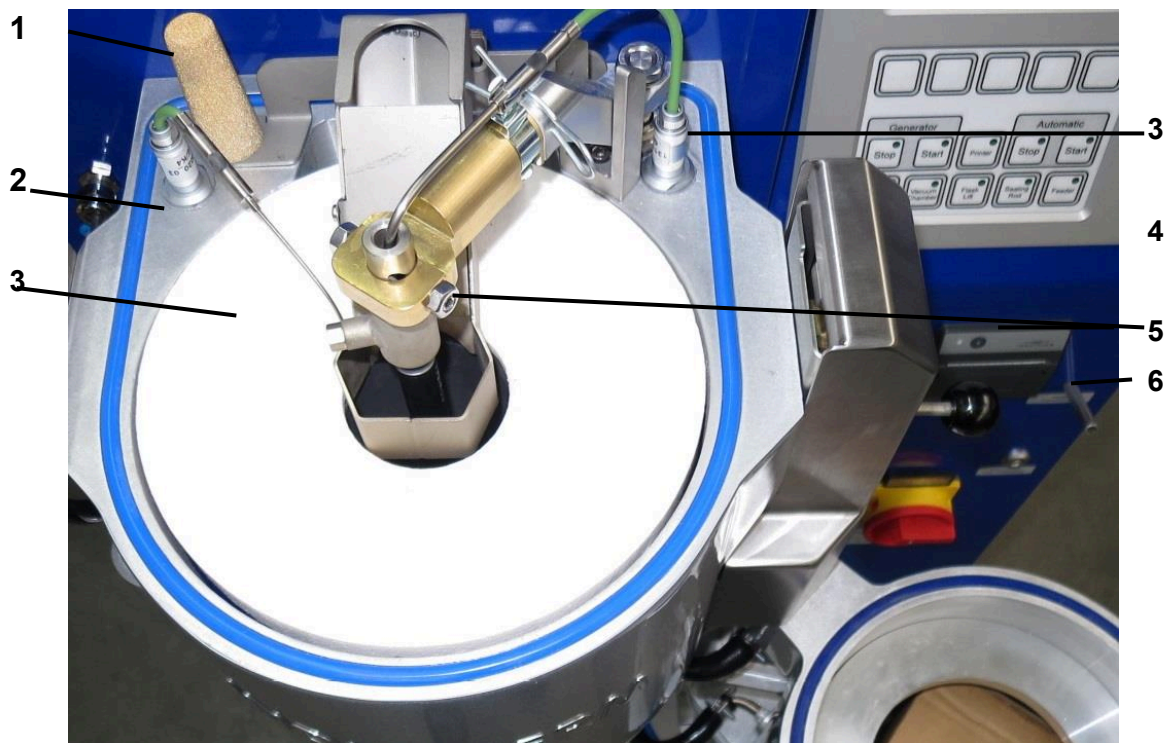

position	designation	Function
1	metal filter C038	Brass filter for vacuum build up.
2	thermocouple socket (option)	Thermocouple connector for wall measurement if you work with centre measurement additional (option).
3	filling cone	Top insulation and help for filling crucible.
4	thermocouple wall	Thermocouple for the crucible wall measurement.
5	flask	Holder for the flask thermocouple.
6	flask	Socket for the connection of the flask thermocouple.
7	sealing rod	For closing the crucible bottom hole by a self-rotating mechanic.

Figure 5: Illustration of the self-rotating rubbing mechanism

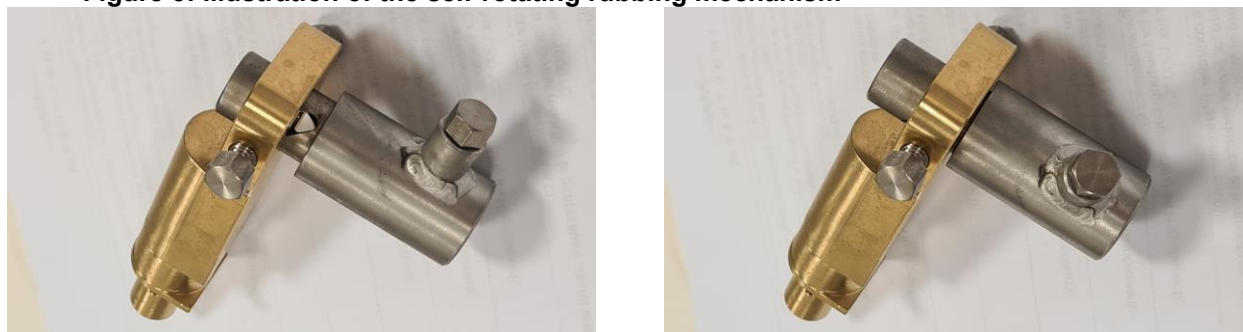

4.5 Feeder system

Figure 6: refill system

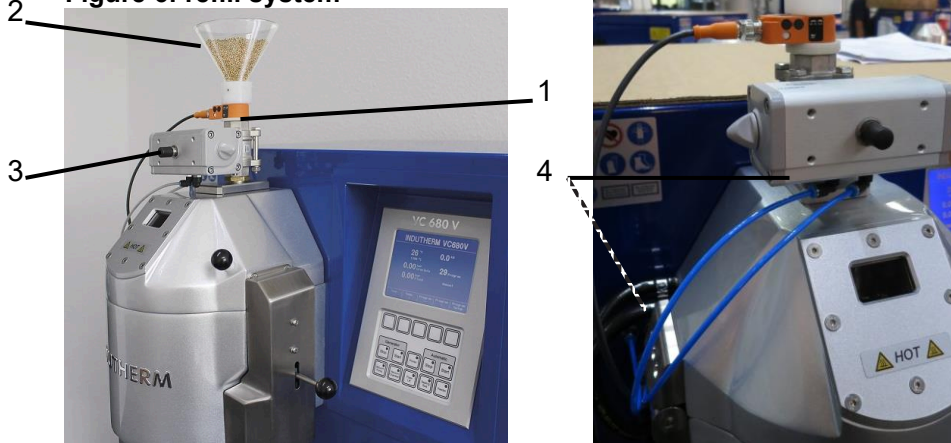

position	designation	function
1	feeder grain detector	Metal detector for detecting metal. When metal is present, the light at the detector goes on and if no metal is present, the light from the sensor is off. The sensor is set by Indutherm..
2	refill container/funnel	Please fill in the previously measured amount of material here. The feeder can not dose. The full refill quantity is filled in.
3	pneumatic cylinder	Opens and closes the bottom opening of the funnel.
4	air supply	Here, the compressed air for the pneumatic cylinder is connected. It has been removed for transport and must be correctly connected during installation, see feeder button function (light on - OPEN, light off - CLOSED). The feeder button has a delay function to prevent short-sequential keys.

Figure 7: adjustment of grain detector

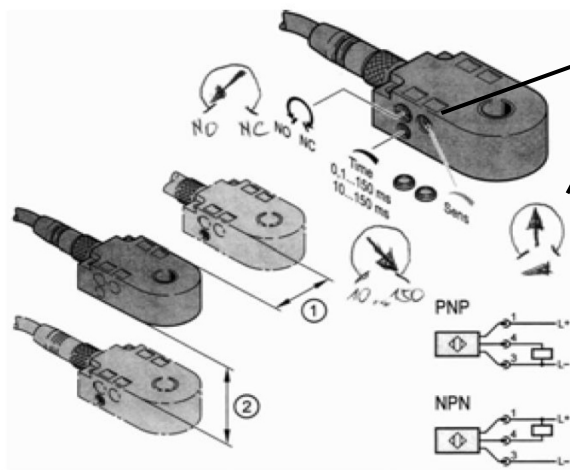

Sensitivity adjustment control

After a few hours of operation it may be necessary to slightly adjust the setting by 5° to the left or right. Simulate with a normal screwdriver "metal" in the detector opening and adjust with a fine watchmaker's screwdriver, please until the LED reliably indicates the metal is applied.

4.6 Additional gas tank

Figure 8: additional gas tank

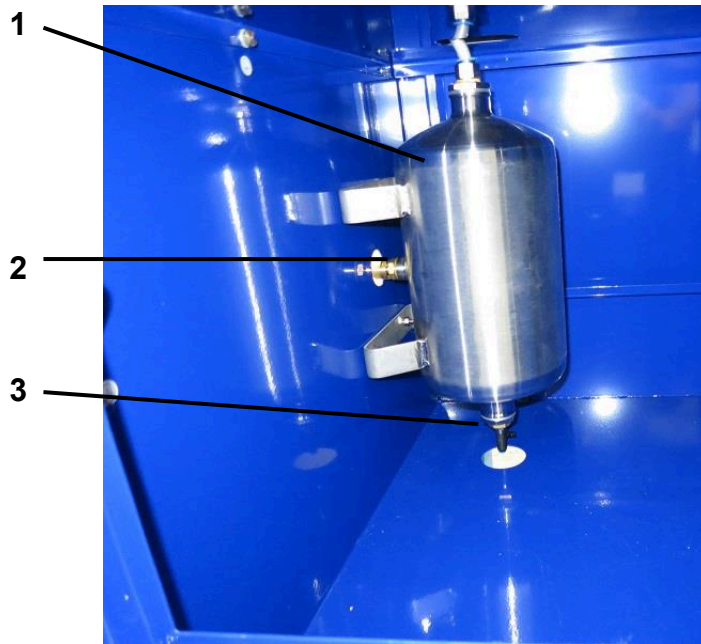

position	designation	function
1	additional gas tank	Accumulator for protective gas for rapid pressure build-up in the crucible.
2	safety valve	9 bar safety valve.
3	release valve	Here the pressure can be carefully released by hand if the machine goes into transport.

4.7 Special options

4.7.1 Centre- and wall measurement (Dual measurement)

Figure 9: option – dual measurement

Recommended device specific values

Para-meter	Remark	VC650V	VC680V
		12.0kW	12.0kW
		Gen. F 8KHz 3x 400V 3x 230V	Gen. F 8KHz 3x 400V 3x 230V
		TC Wall Crucible 78	TC Dual Crucible 78 (Entwurf)
006	TS Cru. WallDeltaMaxT K	0	50
007	TS Cru. WallDynamic	100	300
010	TS0 Cru. BasePower	25	25
011	TS0 Cru. BasePowerCorrection	0	0
012	TS0 Crucible P	15	8
013	TS0 Crucible I	25	150
014	TS0 Crucible D	25	50
015	TS0 Cru. I suppress	15	100

4.7.2 Granulation tank

Figure 10: granulation tank

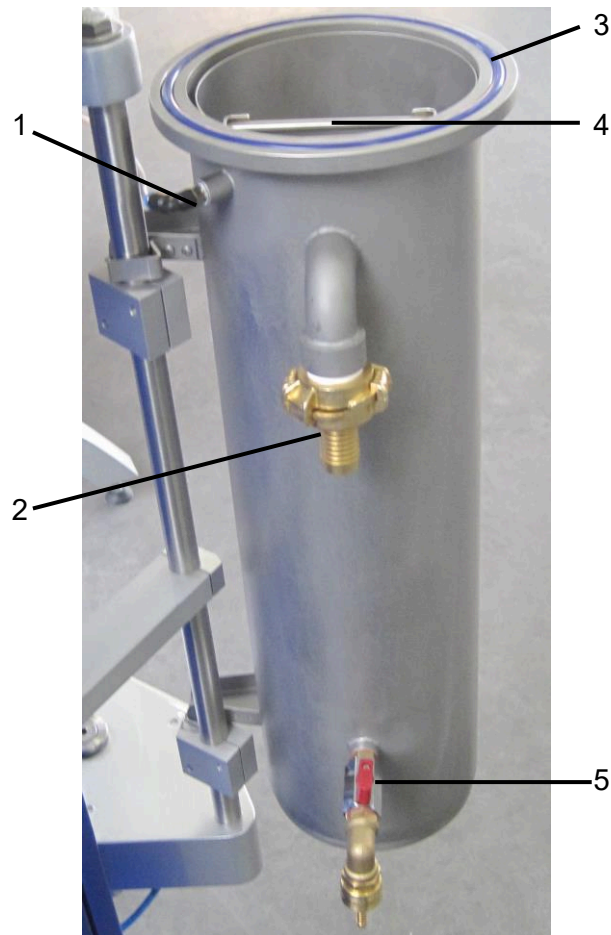

position	designation	function
1	protective gas entry	Here you can supply additional protective gas.
2	water outlet	Usual water outlet for water hose with diameter 21 mm.
3	O-Ring	This is for sealing of the barrel without a gap.
4	Inside barrel with lever	Removable inside barrel with fast emptying function.
5	fresh water input	Control for the fresh water input. Here you connect 8 mm diameter hose of tap water or second cooling system.

Figure 11: example of second cooling system



4.7.3 Hinged window

Figure 12: option vacuum sealed hinged window

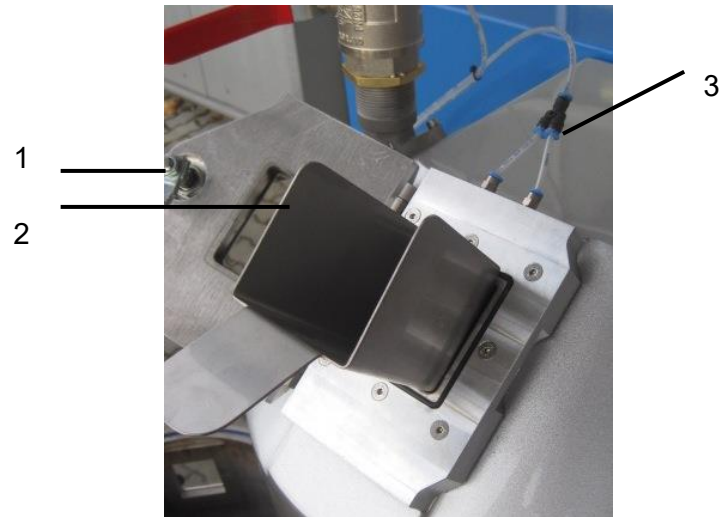

position	designation	function
1	locking lever	Lock the window.
2	slide	For refilling the crucible.
3	protective gas supply	Reducing the glass from fogging.

4.7.4 Inductor 110 mm

Figure 13: Service at inductor 110 mm

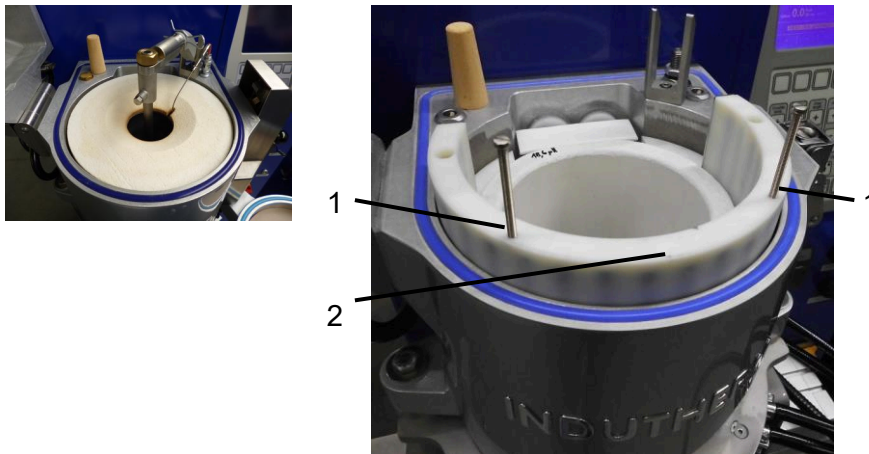

position	designation	function
1	screw M4x50	Two screws as tool for taking out of ferrite cage during cleaning and service tasks.
2	cage with ferrite tubes	Two parts of ferrite cage with ferrite tubes.

4.7.5 Flask height with 260 mm (10") with 'special-pin' 71114321

Figure 14: standard 240 mm

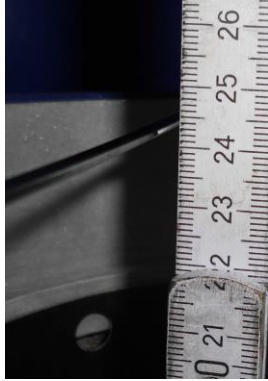

Figure 15: Pin-option 71114321

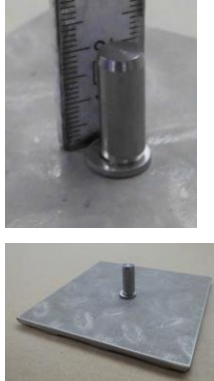
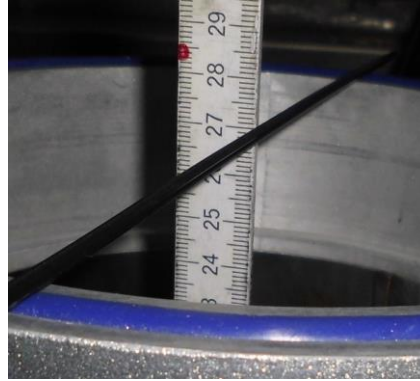

Figure 16: possible height 260 mm



5 Transport

Danger!

Lethal injuries with wrong transport by fork lift truck.



- Take care of the right position using transport device to avoid tilting of the system.
Pick up the system only from the side, because centre of gravity is in the upper front third.
- If the fork is too small or too narrow adjusted there is a danger of system tip over from the mean of transportation.
- Please wear appropriate personal protective equipment (PPE).
- Let do transportation only by trained personnel.



There is no guarantee for damages because of failure to comply transport regulations.

- > Transport the system always with fork lift truck or pallet truck.
- > Please protect the induction coil against damages with sturdy foam material.
- > Transport the system upright. If the machine is transported in another position, the system will be damaged.
- > Take up the system from the side.

Figure 17: lifting the weight



6 Mounting and commissioning

6.1 Safety advices for mounting



Danger!

Only experts may work at the electrical equipment.



Danger!

Observe the mains supply to requirements of the local electricity supply company, the VDE and the local electricity company.

Close the system always via the 5-pin power plug to the power supply. Improper connection can result in injury and damage to the system.



Attention!

Check before connecting the system, whether the existing mains voltage corresponds with the operating voltage of the system. If the voltages do not match, the system can be damaged.

6.2 Mounting process

Place the system in a clean, dry place horizontally on. The ground must be firm and level. To the machine the following work area must be kept free: left and right of the door 1.5 m and behind the system 0.5 m. In front of installation should be at least 1.5 m of free work-space.

Cooling air may not exceed 35 °C (95 °F) and should be free of contaminations.

Establish supply connections according to information in chapter 3 "technical data":

- current,
- compressed air
- protective gas,
- cooling water and
- vacuum.

Examine supply lines and connections on damages.

Only after the correct connection of all supply and connecting systems, the system may be put into operation.

6.3 Apply supply connections

6.3.1 Power supply

The electrical connection may only be performed by a specialist. Note the information specified on the nameplate rated voltage or frequency.

The 3-phase power supply may differ max. +/- 10% from the rated voltage.

The system is supplied with a 32A CEE plug. The system **should** only be connected via this 5-pin power plug to the power supply. The on-site to install socket must be equipped with appropriate fuses (slow).



INCREASED LEAKAGE CURRENT:

Due to the built-in EMC filter, the system has an increased leakage current.



The fuse on the building electrical system must be checked. If you use a residual current circuit breaker (RCD), the RCD will probably start when the connector is plugged in, since not all 3 phases start uniformly and a high leakage current is generated. After plugging the plug, switch on the RCD.

Figure 18: RCD



On site must be provided by a loop impedance measurement of the detection of the switch-off of the overcurrent protective device.

6.3.2 Cooling water

Cooling water supply is connected to the machine by 2 hoses with inside diameter of 13 mm (before 2018: 8 mm).

Water pressure must be 2.5 bar at minimum and don't exceed 5 bar. Water outlet has to be pressureless.

Input water temperature should be between 15 °C (59 °F) and 25 °C (77 °F). To prevent damage caused by condensation is especially recommended temperature area of 20 to 25 °C (68-77 °F).

Lime concentration should be between 3 and 8 German hardness degrees. The water should be free of pollutions.



Warning: The cooling water is continuously running through the VC680V even in case the mains switch is off.

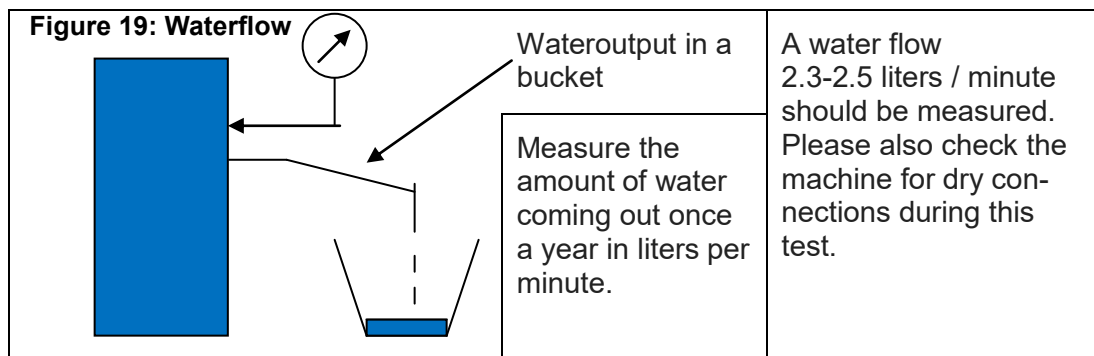

6.3.3 Compressed air

The compressed air must be provided by a service unit with an oil separator and a pressure of 8 bar. The use of lubricated compressed air is not recommended. Please use an air hose with an inner diameter of 6 mm for the connection.

6.3.4 Protective gas

The protective gas only nitrogen or argon may be used with a purity status of at least 99.9 %. The supply is effected via a compressed air hose having an inner diameter of 6 mm. The inlet pressure must not exceed 8 bar. Gas consumption is about 1 - 3 l / min. Please use only a constant pressure regulator.

Figure 20: constant pressure regulator



2x gauges in
bar/PSI/kPa/MPa.

Never in liter/minute (l/min)!!!!

6.3.5 Vacuum

Here, a vacuum pump with a suction capacity of at least 21 m³ / h and a final pressure of 2 mbar should be connected. The connection must be via a special vacuum tube with a cross section inside of 13 mm carried out (article no. 40200010).

Oil level and air filter should be checked weekly.

The first oil change should be carried out after 100 operating hours.

Later we recommend regular oil changes (depending on the work process) all 500 - 2000 operating hours, but at least twice a year. You need special vacuum pump oil (item number 15000910).

The oil filter and the exhaust filter should be replaced at every second oil change.

For detailed information, please also refer to the operating manual in maintenance of the vacuum pump.

6.3.6 Gas outlet

Exit to the pressure reduction. This output must be kept clear at all times.

6.3.7 Vacuum pump (mains socket 16 A)

This socket is only intended for connection of a 3-phase vacuum pump (400 V AC) with a maximum output of 1.5 kVA. Internally there are backup fuses for this output. During commissioning the correct direction of the vacuum pump must be checked, otherwise the pump will be destroyed.

6.3.8 RS232

At this plug our serial cable can be connected (article no. 50500060). For the use an internal cable at the generator must be switched with the actual attached modem cable.

6.3.9 USB socket (universal serial bus)

Here, the machine can be connected to a PC. Use the data management software provides by Indutherm to read system data and casting programs. It can also record casting logs electronically.

Figure 21: data management software menu

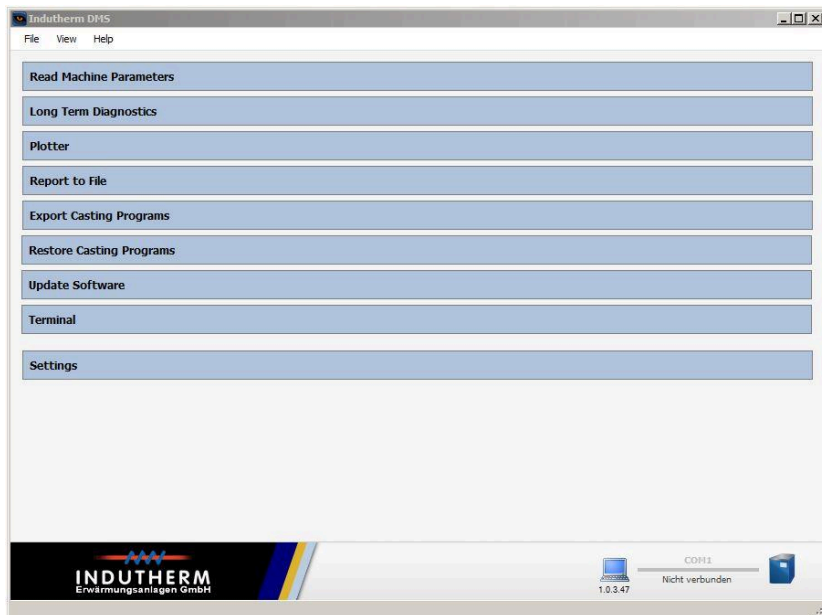

Figure 22: casting log

```

-----
INDUTHERM
-----
Material : .....
Quantity : .....
Batch    : .....
Date     : 22.11.2016 15:13:07
-----
Program  : P027
-----
Temperature      600 °C
                  ( 1200 °C )
Washing while heating 2 x
Flask/ingot while heat No.
Flask temperature  0 °C
Melting pressure   0.20 bar
                  ( 0.16 bar)
Melting time      30 s
                  ( 155 s )
Casting mould     Flask
Casting mode      Manual
Pre cast vacuum   0 s
Casting pressure start 0.2 s
Casting pressure  2.00 bar
                  ( 1.98 bar)
Flask pressure    -1.00 bar
                  (-0.86 bar)
Vibration time    20 s
Vibration sweep   No
Cooling time      30 s
                  ( 30 s )
Cooling time p.-less 0 s
                  ( 0 s )
Vacuum chamber open Automat.
-----
Current values within brackets
V0650V  000 0102  F0133 M11312
-----
    
```

6.3.10 LAN-socket (Local Area Network)

Machine can be connected to a network.

6.3.11 Internal modem

The machine is equipped with a modem on mobile phone base. This can read from the induction generator, which may be for debugging and fine-tuning your machine useful of Indutherm service to your desired machine data. The free use is valid for 10 years with occasional use.

7 Operation

7.1 Safety advices for operation



Caution!

Examine all consumables, insulations and hoses before switching on. Check for damages and cleanliness, especially crucible and insulations. Operate the system only when it's free of damages.



Warning!

Risk of burning on hot surfaces and hot metal (until ~ 1700 °C). Wear always personal protective equipment when you work with the machine.

Utmost caution during using graphite crucibles and graphite moulds. The heat of these parts is only visible when the temperatures are over 500 °C.



Danger!

Risk of burns. The surface of the bell can be very hot, depending on the working temperature.



Danger!

Danger of crushing / shearing by swivelling the vacuum chamber.

The vacuum chamber must be pivoted with the hands at middle height of the chamber surface.

Figure 23: Hand centered

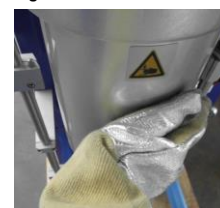

Danger!

Danger of crushing / shearing by moving the flask holder. By raising or lowering the flask holder injuries can happen.



Danger!

Risk of burns. If metal is melted without the supply of protective gas, can cause a flash fire or explosion when opening the bell.

Melt at temperatures above 500 °C always with protective gas. Use as a protective gas exclusively argon or nitrogen.

**Attention!**

At crucible temperatures over 100 °C the cooling water supply must be switched on. If it is not turned on, the inductor will be destroyed. If cooling water supply fails, the heating system immediately is turned off. Inspect the system for damage before putting back into operation again.

7.2 Changing casting parts**7.2.1 Removal**

- > Open the bell-lid. Take out thermocouples.
- > Lift sealing rod with button “sealing rod” and remove it.
- > Remove “old crucible” and possible insulations.

7.2.2 Mounting

- > Install “new” crucible and possibly “new” insulations.
- > Put in sealing rod and close it with button “sealing rod” at front panel.
- > Put in thermocouples.
- > Twist sealing rod a few times to left and right (rub surfaces), so that the crucible is reliably closed.
- > Close bell-lid.

7.3 Front panel

7.3.1 LCD screen after mains switch on

Figure 24: main screen

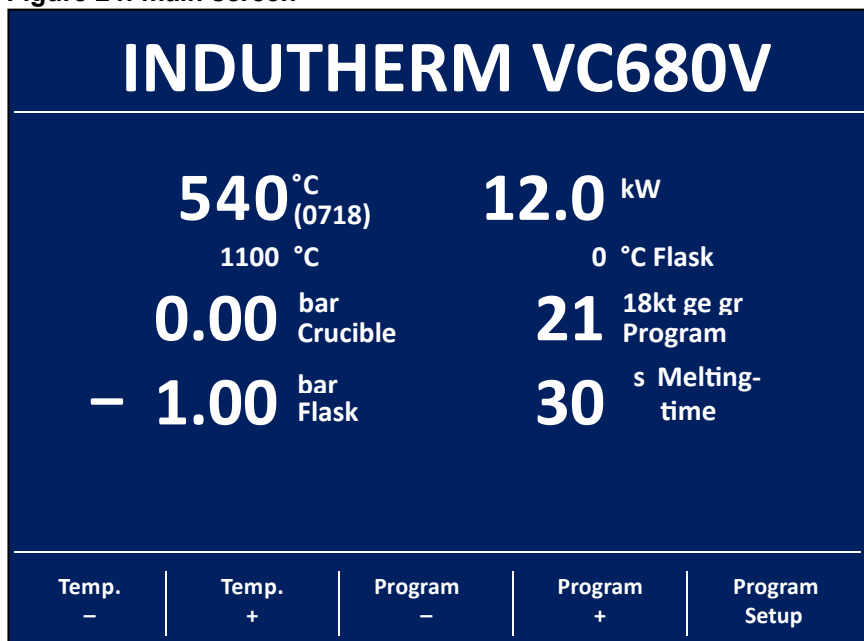

upper area =
Actual state of machine

lower area = options

Display in the upper area:

540 °C	Actual crucible temperature of wall measurement.
718 °C	Actual crucible temperature of wall measurement, when working with dual measurement. Main measurement would be the centre measurement.
1000 °C	Set temperature.
0.00 bar Crucible	Actual pressure in crucible area -1.00 to 3.00 bar.
-1.00 bar Flask	Actual pressure in the vacuum chamber (-1.00 to 0.00 bar).
12.0 kW	Actual heating power in kW
0 °C	Flask temperature.
21 Program	Actual program.
18kt ge gr	Program name (18 kt yellow gold alloy, big parts).
30 s Melting time	Time.

Display in the lower area:

Temp -	Lowering set temperature also during program.
Temp +	Increasing set temperature also during program.
Program -	Program no. 20 will be selected.
Program +	Program no. 22 will be selected.
Program Setup	Allows the jump to the parameter level of the program 21.

7.3.2 Program change page 1

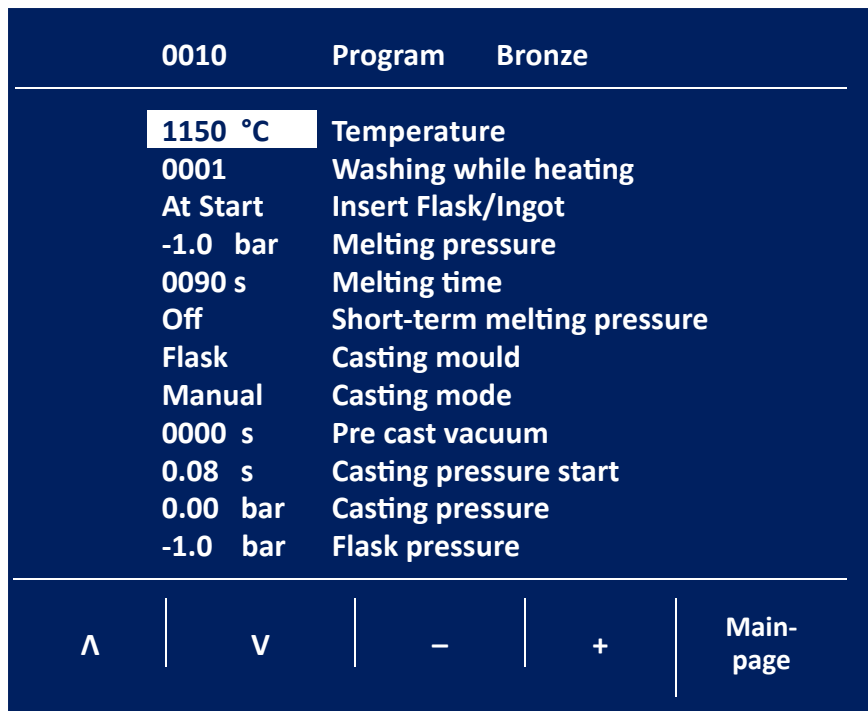

Figure 25: Program parameter page 1

upper area = Parameter

lower area = options

Display in upper area:			
0010	Program	'0' to '99'	Actual selected program to modify.
1150 °C	Temperature	'10' to '1300' °C	Set temperature inside crucible (depends on type of thermocouple).
0001	Washing while heating	'0' to '5'	Number of washing cycles during the heating process (evacuation to full vacuum, then backfill with protective gas).
At Start	Insert Flask/Ingot	'At Start'	The mould will be placed in the mould chamber before the washing cycles and heating process.
		'Bef.cast'	The mould would be inserted at a later moment during the heating process before (bef.) casting.
-1.0 bar	Melting pressure	'-1.00' to '3.00' bar	Set value for the gas pressure in the crucible chamber during the melting process.
0090 s	Melting time	'1' to '600' s	Set time for holding set temperature.
Off	Short-term melting pressure	,Off' to ,60 s'	For melting without a vacuum in the flask chamber: The vacuum is only built up when the material is liquid. After this the material is poured off. Suggested experiment value is 12 s. SW800.0144 and higher.

Flask	Casting mould	'Flask'	flask without flange – two chamber system with differential pressure.
		'Flask FI'	Flask with flange (differential pressure)
		'Flask HSC'	<i>under development</i>
		'Ingot'	One chamber system with always similar pressure in both chambers; should be selected if the mould does not allow for a sufficiently good seal between the two chambers, which is frequently the case for ingot moulds.
		'Grain'	Program basic settings for granulating.
Manual	Casting mode	'Manual'	The pouring step must be confirmed manually by the operator by pressing the 'Start' button.
		'Automatic'	The pouring step is initiated automatically after the pouring temperature is reached.
0000 s	Pre cast vacuum	'0' to '20' s	Set value for a quick evacuation time step in the crucible chamber right before initiation of the pouring step; this removes gas from the interior of the mould/flask but avoids extended melting time under vacuum.
00.8 s	Casting pressure start	'0.0' to '20.0' s	Set value for the exact timing at which an overpressure is applied in the crucible chamber towards the end of the pouring step.
0.00 bar	Casting pressure	'-1.00' to '3.00'	Set value of overpressure in the crucible chamber.
-1.0 bar	Flask pressure	'0.0' to '-1.0'	Set value for the gas pressure in the flask chamber during the pouring step; it is created after that the two chambers have been sealed each others by moving the vacuum chamber and flask upward into the position for pouring.

On the bottom level is shown:	
Arrow key up	Move to the set value one position higher (here not possible).
Arrow key down	Move to the set value one position lower (here: to Washing while heating).
-	Lower the set value (here: 1149).
+	Increase the set value (here: 1151).
Main page	Return to the main display.

7.3.3 Program change page 2

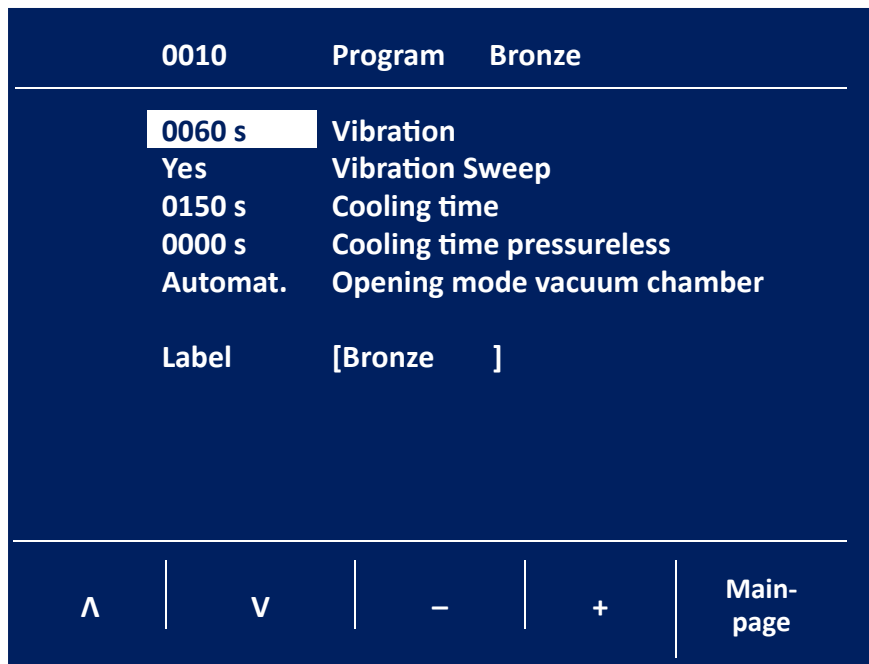

Figure 26: Program parameter page2

upper area= parameter

lower area = options

Display in the upper area:			
0060 s	Vibration	'0' to '60'	Set value for the mould vibration time.
Yes	Vibration Sweep	'Yes', 'No'	Alternating vibration.
0150 s	Cooling time	'5' to '600' s	Set value for the time during which the chamber remain under pressure.
0000 s	Cooling time pressureless	'0' to '600' s	Set value for time during which the chamber remains closed without pressure.
Automat.	Opening mode vacuum chamber	'Manual'	Swivelling out of the vacuum chamber has to be confirmed from the caster with pressing 'Start' button.
		'Automat.'	Swivelling out of the vacuum chamber starts automatically after program is finished.
Label	[Bronze]	'a-z, A-Z, 0-9'	Opportunity to give a name to the actual program using the +/- keys (alphabet capital and small letters, numbers, symbols) and arrow keys (next character spacing).

7.3.4 Predefined casting programs

Figure 27: pre-set casting programs

VC680V							
Material		Bronze	Yellow gold 14 kt (with zinc)	Yellow gold 18 kt	Aluminium	Brass	
Crucible		Graphite	Graphite	Graphite	Graphite	Graphite	
Program no.		10	11	12	13	14	
Temperature	°C	1150	1060	1080	740	1080	
Washing while heating		0001	0001	0001	0000	0001	
Insert Flask/Ingot		At Start	At Start	At Start	At Start	At Start	
Melting pressure	bar	-1.00	0.00	-1.00	-1.00	0.00	
Melting time	sec.	0090	0090	0090	0120	0090	
Casting mould		Flask	Flask	Flask	Flask	Flask	
Casting mode		Manual	Manual	Manual	Manual	Manual	
Pre cast vacuum	sec.	0000	0010	0000	0000	0000	
Casting pressure start	sec	00.8	00.8	00.8	00.8	00.8	
Casting pressure	bar	0.00	0.00	0.00	0.00	0.00	
Flask pressure	bar	-1.00	-1.00	-1.00	-1.00	-1.00	
Vibration	sec.	0060	0020	0020	0060	0060	
Vibration Sweep		Yes	No	No	Yes	No	
Cooling time	sec.	0150	0150	0150	0300	0150	
Cooling time pressureless	sec.	0000	0000	0000	0000	0000	
Opening mode vacuum chamber		Automat.	Automat.	Automat.	Automat.	Automat.	
Label		Bronze	YG 585	YG 750	Aluminium	Brass	
VC680V							
Material		Silver 925 Ingot	Silver 925 heavy	Silver 925 middle	Silver 925 light	Granulate	Test
Crucible		Graphite	Graphite	Graphite	Graphite	Graphite	Graphite
Program no.		15	16	17	18	20	28
Temperature	°C	0950	0980	1000	1020	1150	0010
Washing w. heating		0000	0001	0001	0000	0001	0000
Insert Flask/Ingot		At Start	At Start	At Start	At Start	Bef.cast	Bef.cast
Melting pressure	bar	-0.90	0.00	-0.50	-0.90	0.00	-1.00
Melting time	sec.	0180	0120	0090	0090	0180	0010
Casting mould		Ingot	Flask	Flask	Flask	Grain	Flask Fl.
Casting mode		Manual	Manual	Manual	Manual	Manual	Manual
Pre cast vacuum	sec.	0000	0000	0000	0000	0000	0000
Casting pr. start	sec	00.0	02.0	01.2	00.8	00.0	02.0
Casting pressure	bar	0.00	0.50	1.00	2.00	0.50	0.50
Flask pressure	bar	0.00	-1.00	-1.00	-1.00	0.00	-1.00
Vibration	sec.	0060	0060	0045	0030	0000	0010
Vibration Sweep		No	Yes	Yes	Yes	No	No
Cooling time	sec.	0300	0300	0300	0300	0010	0020
C. t. pressureless	sec.	0000	0000	0000	0000	0000	0015
Opening mode VC		Automat.	Automat.	Automat.	Automat.	Automat.	Automat.
Label		Ag925Ingot	Ag925heavy	Ag925mediu	Ag925light	Granula.	InduTest

7.3.5 System parameter

If you start from the main page and you press 'Program Setup' for five seconds you get access to the system parameter level.

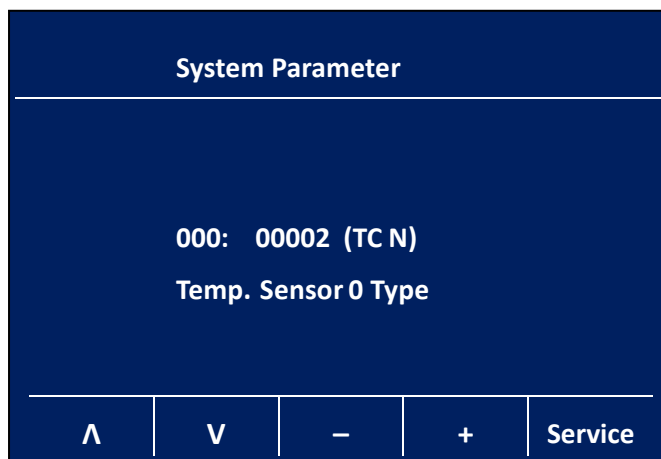

Figure 28: System parameter

Note:

Please refer to the explanations for the parameters in the attachment software documentation. The adjusted values should be changed with care and usually after consultation with the Indutherm service staff.

Display-functions:		
000:	00002	Selected parameter: 000 Value of parameter is 2, which means here thermocouple type N (TC N) is activated.
V		With pressing 'arrow down' you get to previous parameter (here not possible).
Λ		With pressing 'arrow up' you get to next parameter 001.
-		With pressing '-' you decrease the value to 1.
+		With pressing '+' you increase the value to 3.
Service		With pressing the button near to this word you see information of 'Service Info Page 1' with several serial numbers.

7.3.6 State Level

By pressing the 'Service'-button once, you see the software ID, generator number and machine number.

Figure 29: Service-Info-Page 1

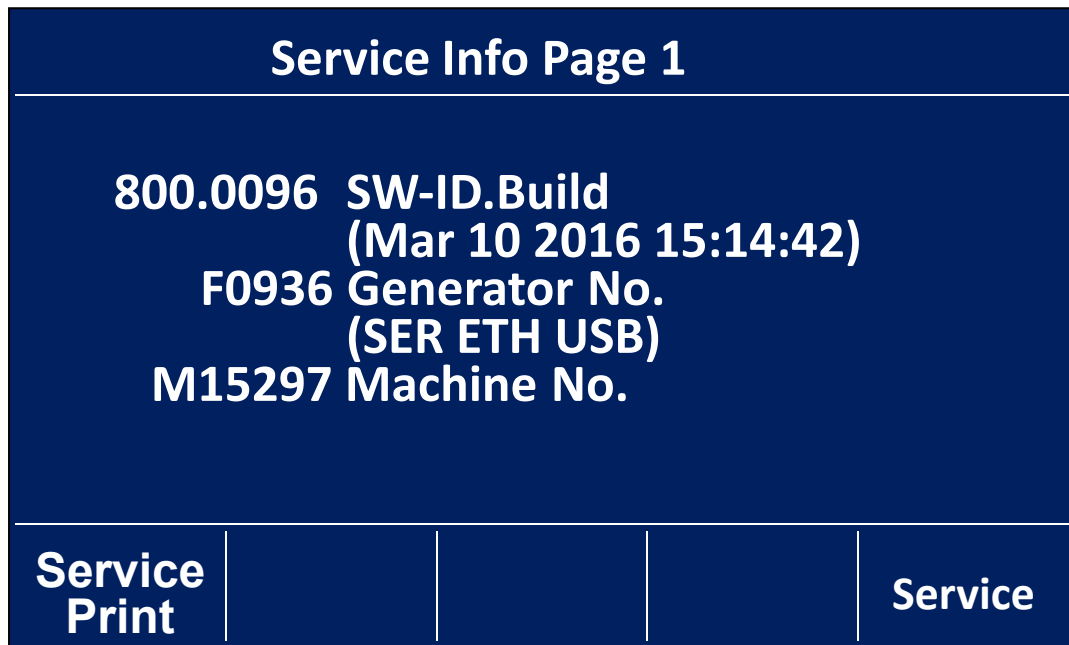

Pressing 'Service' second time display switches to the second service info page amongst other with important information on the cooling water flow, generator temperature, machine state and signal strength of inbuilt modem.

Figure 30: Service-Info-Page 2

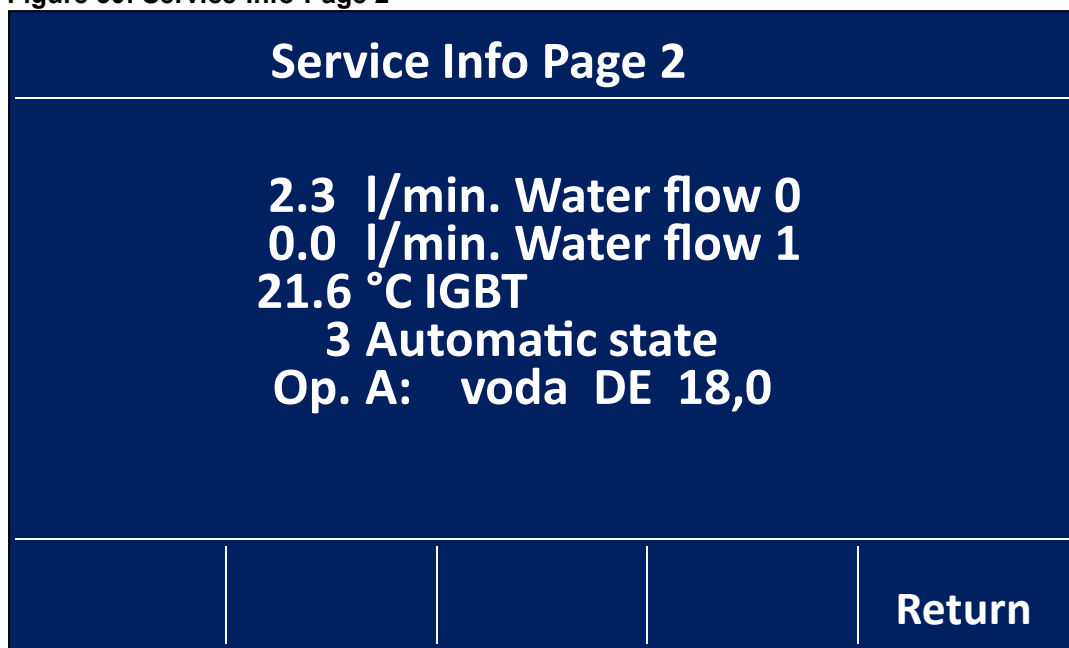

After pressing 'Return' switch display back to main page.

7.3.7 VC680V Front panel below display

Figure 31: Front panel below display

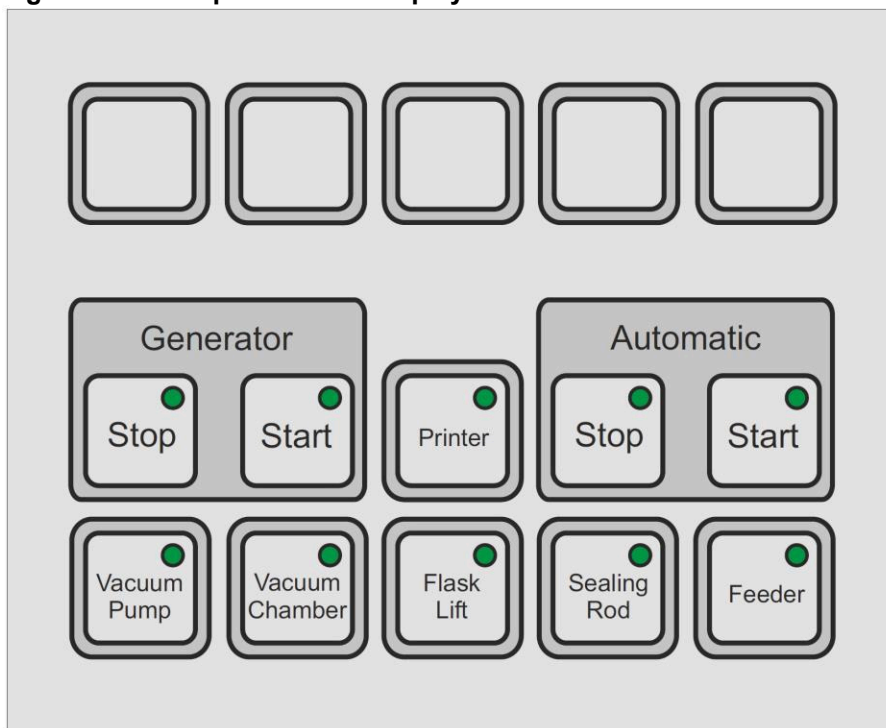

Manual control:	
Generator Start	By this button you can start heating from generator. Switched on generator regulate for the set temperature (see above 'temperature').
Generator Stop	Stops heating (if not operating in program).
Printer	With enabled printer (light in button is on) starts a casting report print out at the end of the casting process. For service reasons: you'll get full parameter printout when you press button printer for five seconds.
Automatic Start	With this button the selected casting program starts and its parameter will be executed from the memory. Starts pausing program (LED is blinking).
Automatic Stop	Pauses an automatic program, if pressed once and stops the program if you press it twice.

Vacuum Pump	Switching on and off the vacuum pump, when the pump is connected to the backside socket from the machine.
Vacuum Chamber	Opens the vacuum chamber. Chamber will be closed automatically when it is swivelled completely under the crucible chamber. During granulating process lifting and lowering of the granulating tank.
Flask Lift	Lift and sink of flask lift. This function is only possible with closed vacuum chamber. With open chamber lifting and sinking is performed automatically.
Sealing Rod	With pressing this button the sealing rod opens or close, which let flow liquid material in the flask or granulation tank when it is requested. With software state 800.0104 and higher (see service info page 1), a safety

	system is installed, which monitors a swivelled out vacuum chamber. You can deactivate the warning W077 by pressing the button 'sealing rod' for 3 seconds. This is useful when you want to clean an empty warm crucible, but the vacuum chamber is swivelled out.
Feeder	Attention: Does not work with overpressure! By pressing the button, the LED lights up and the entire dose in the funnel is directed into the interior of the crucible chamber via a chute into the crucible. If the LED is dark, the supply path is closed. Please check the function during initial startup. The Feeder button reacts with a delay time when switching on and off, in order to avoid accidental double tapping (bouncing). See system parameter 133 for minimum open time with standard setting of 5 seconds (2...10 s possible).

7.4 Protective Gas flow

Protective gas supply for pressure regulation in the crucible occurs automatically. For safety reasons: there is continuous flow of protective gas at temperatures over 500 °C, because there is danger of blow up.

7.5 Casting

Before starting check chambers, crucible and crucible shield for dirt, residues or possible damage. It is recommended to use a **vacuum cleaner** for the entire inductor housing and mould chamber. The sinter filter (left side of the sealing rod) should be twisted out and cleaned with compressed air.



With using of compressed air wear a dust proof mask and must not blow in the room.



Program selection:

11 pre-defined program with recommended parameters are stored for standard VC series and processing of conventional metals (e.g. silver). Program-places are 10-18, 20 and 28. Program 28 = one test program from INDUTHERM for system check without heating power.

A suggestion for a general casting process:

1. Open cooling water, compressed air and protective gas supply.
2. Switch on vacuum casting machine and vacuum pump, for optimum perfor-

mance always keep the vacuum pump running for at least 30 min to heat up (The vacuum pump attached to the casting machine switch on by itself in program with selected washing or low vacuum).

3. Adjust or select the wished program.
4. Twist (turn) the sealing rod slightly in the crucible hole and fill in the material.
5. Start the program process (Key 'Automatic Start').
6. Wait for command 'Set in flask'. Confirm it with pressing key ,Automatic Start'. Swivel out vacuumchamber. Put in flask. Close vacuum chamber.

Figure 32: Example command "Set in flask"

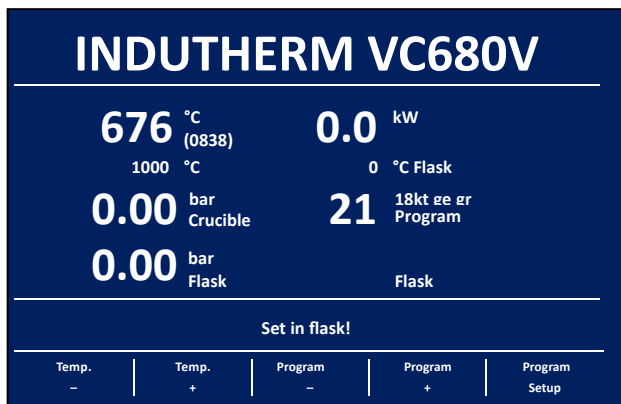

7. Wait for command 'casting'. With a look through the window check the melted alloy. Confirm command with button 'Automatic Start' when LED is flashing in the key (this step is only necessary at manual casting mode).
8. Wait in the end for flashing key 'Automatic Start'. Press it (this step is only necessary at manual casting mode). Then swivel out vacuum chamber and take out flask.

A new casting cycle can start beginning with step 3.

Vibration device

The machine VC680V is equipped with a vibration device, which is below of the traverse of the vacuum-chamber.

Vibration starts 1 second after opening of sealing rod in the automatic program mode, if there is a vibration time bigger than 0 programmed.



Note:

At our webpage www.INDUTHERM.de you'll find a training video of VC650V.

Suggestion for a simple casting process (sufficient for many applications):

Program parameter to adjust:

Temperature:	ca. 100 °C over melting temperature of the alloy (Consider the recommendation of the alloy manufacturer).
Melting pressure:	+0.00
Melting time:	030
Casting pressure:	+0.60
Casting pressure start:	001
Cooling time:	180
Casting mode:	Automat.

1. Open cooling water, compressed air and protective gas supply.
2. Switch on vacuum casting machine and vacuum pump (connected vacuum pump switch on by itself within program).
3. Adjust program with above mentioned parameters.
4. Twist (turn) the sealing rod slightly in the crucible hole and fill in the material.
5. Start the program process (Key 'Automatic Start').
6. Wait until the material is melted completely.
7. Wait for command 'Set in Flask'. Confirm it with pressing key 'Automatic Start'. Swivel out vacuum chamber. Insert flask. Close vacuum chamber (Remark: Casting occurs with this program about 15 seconds after closing vacuum chamber. Important: Close vacuum chamber definitely after alloy is fully liquid).
8. Wait for the automatic opening of the vacuum chamber. Swivel out vacuum chamber and take out flask.

A new casting cycle can start, beginning with step 3!



Recommendation INDUTHERM:

Before you do your first castings with your material let run the test program [28](#) at room temperature with cold flask.

7.6 Possible causes for dissatisfying casting results

Dissatisfying casting results can have various causes and, depending on the material, can have various effects. The following "check list" is to help find the different causes:

1. Casting temperature is too low/too high.
2. Flask temperature is too low/too high.
3. Configuration of flask is disadvantageous ("branches" too thin or too close to the top).
4. Flask is not totally heated up (at least 2 hours on end temperature).
5. Flask was slaked too early/too late.
6. Contamination in the alloy (for example "bad copper").
7. Material was not pre-alloyed/granulated.
8. Investment for flask was bad/old.
9. Eventually not enough protective gas or the gas had water inclusions.
10. Wrong crucible position (different crucible temperatures), because of worn bottom insulation.
11. Not enough vacuum inside the vacuum chamber (at least - 0.9 bar for good casting).
12. Vacuum was turned on too late/turned off too early.
13. Contamination in the investment because of wax residues (steam out flasks).
14. Graphite contamination (use ceramic insert or crucible of better graphite quality).

Please note that INDUTHERM cannot be held responsible for dissatisfying casting results.

7.7 Flask structure

Figure 33: sectional view of flask

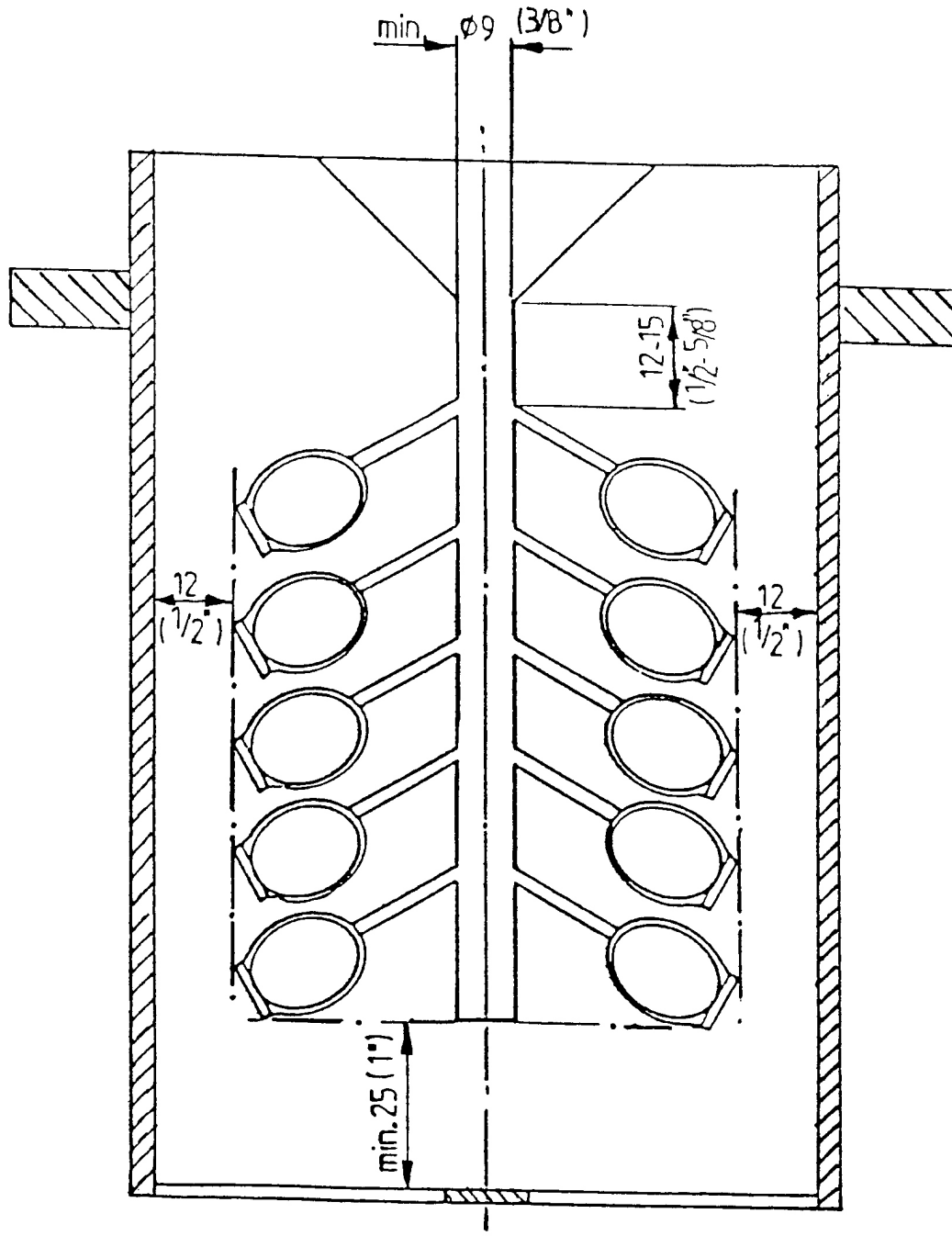

Figure 34: flask without flange and holes



Note:

The principle of the machine is based on the high gas flow through the machine. Please use only flasks with holes on the side.



7.8 Granulating

Before starting check crucible, sealing rod and crucible insulation for dirt residues/possible damages. It is recommended to use a **vacuum cleaner** for the entire inductor. The metal filter (left of the sealing rod) should be taken out and cleaned with compressed air. Use a dustproof mask and blow not in the room!

A crucible with a hole of a 2-mm-diameter is recommended.



Advice!

For producing granules of even smaller diameter, you can buy crucibles without hole for self-drilling of, for example, 1 mm hole.

Figure 35: crucible without hole



For granulating you have to adjust in *Casting Mould' the value 'Grain'.

Before you start please adjust your parameter. You can choose par example pre-set program 20.

Temperature: right adjustment depends from the alloy (about 100 – 200 °C over melting point).

Washing while heating: please set it on 0001, if you melt alloys with zinc (combined with melting pressure of 0.00 bar). Adjust it at 0000, if melt under vacuum alloys without zinc content and melting pressure of -1.00 bar.

Melting pressure: from '0.00' to '-1.00 bar', depending of the alloy.

Melting time: depends of the metal quality.

Turbo Pressure Maximum: '0.50' to '1.00 bar', is a kind of turbo pressure function, to blow material residues through the pouring hole after granulating.

0020	Program	Granulate
1150	Temperature	
0001	Washing while heating	
Later	Not used	
0.00 bar	Melting pressure	
0180 s	Melting time	
Grain	Casting mould	
Manual	Not used	
0000 s	Not used	
0.00 s	Not used	
0.50 bar	Maximum Granulating pressure	
0.00 bar	Not used	

∧	V	-	+	Main Page
---	---	---	---	-----------

Figure 36: Program parameter granulating page 1

Upper area = parameter

Lower area = Options

0020	Program	Granulate
0060 s	Not used	
Yes	Not used	
0150 s	Not used	
0000 s	Not used	
Automat.	Not used	
Label	[Granulate]	

∧	V	-	+	Main-page
---	---	---	---	-----------

Figure 37: Program parameter granulating page2

upper area= parameter

lower area = options

Suggestion for a granulating process:

1. Switch on cooling water, compressed air and protective gas supply.
2. Fill the granulating tank with water until overflow.
3. Switch on VC680V at the mains switch.

Figure 38: adapter for flask chamber

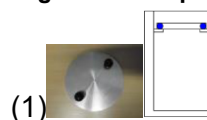

4. Close the flask chamber avec the appropriate flask chamber-adapter (1).
5. Please press 'Generator-Start' in left area of front panel. Protective gas will be applied automatically at temperatures over 500 °C.
6. If the set temperature is achieved, twist the sealing rod thoroughly in the crucible bottom hole (rotating movement) and fill in the material. Please press key "Automatic Start" at the right side of front panel.
7. Follow commands in the display like 'Swivel in grain tank'.
If the flask chamber is opening, then please swivel it completely out.
Swivel grain tank completely under crucible chamber.
Press blinking button 'Automatic Start' again.
Now you see new buttons under the front panel like for instance 'sealing rod' and 'Grain pressure'.
When the alloy is liquid, please regulate the water flow through the nozzles in the grain tank in such a way the water is moving, but not squirting.
8. Depending of the alloy, the metal should maintain the temperature for a few minutes or mixed with a stirring rod.
9. Open the sealing rod with pressing the button 'sealing rod'.
10. When the crucible is not completely empty, remove residues by pressing button 'Turbo pressure' = 'graining pressure'.

If you want to continue with the same alloy, start with step 4 again.

11. Press the button 'Generator Stop', for stopping heating.
12. Swivel grain tank on the left side and take out insert.

Figure 39: granulating insert



Take out insert.

Pour out the water.

Take out material.

7.9 Casting reports

As you know a good casting result depends from many causes: investing material, used alloy, de-wax-process and of course from the INDUTHERM casting machine and its settings.



Advice:

Save your casting reports right from the beginning.

You can collect them and glue in a folder.

Figure 40: File for casting reports

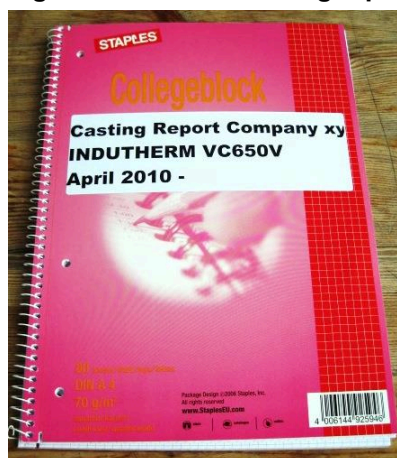

Figure 41: Example print out



Experiences of INDUTHERM:

Every customer can get problems with castings any time. With casting reports you can detect changes for smart troubleshooting. Without casting reports it is more difficult.

7.10 Error diagnosis

There are two types of disturbances.

- Error and
- warnings.

Whenever an error occurs the heating stops, and an error code will be on display.

With slight disturbances you see only a warning code in display.

7.11 Troubleshooting

Only an expert should open the machine.

Disturbance	Reason
Machine can't be switched on.	<ul style="list-style-type: none"> • Mains voltage missing.
Heating don't work.	<ul style="list-style-type: none"> • Cooling water supply not switched on („E010“). • Compressed air supply not switched on („E011“). • Protective gas supply not switched on („E013“). • Thermocouple not put in or faulty („0FbE“). • Generator overheated (too hot, „E021“). • Another error („Exxx“). • Exhibition mode activated (P.155 = 0?).
Temperature indication not right.	<ul style="list-style-type: none"> • Wrong thermocouple adjusted, see annexe. • Thermocouple faulty („E041“). <p>Because of this the generator can switch off!</p>
Low generator output	<ul style="list-style-type: none"> • Set value of temperature regulator too low.
Bad pressure build up/release („E081“)	<ul style="list-style-type: none"> • Bad flask sealings. • Dirty flange of flask. • With vacuum (vacuum supply faulty).
Bad vacuum at flask („E082“)	<ul style="list-style-type: none"> • Bad flask sealing. • Dirty flange of flask. • Vacuum supply faulty. • Filter of vacuum pump is dirty.

If you have additional error messages Exxx, then please see last pages of software documentation in annexe. Or you search in our Webshop. You'll find error document typing in the ‚Exxx‘-number. Please replace W with E for search.

7.12 Diagram casting flasks without flange

Figure 42: Flasks without flange

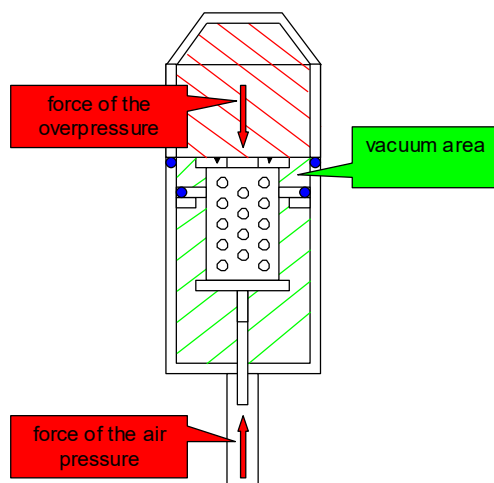

Possible reasons of losing vacuum:

- 1.) O-Ring of vacuum chamber is not OK.
- 2.) Flask top surface is not flat enough.
- 3.) Silicon ring is missing or faulty.
- 4.) Flask cylinder is not in 'up' position.
- 5.) By using overpressure on the crucible area you need 8 bars air pressure. With 6 bars pressure the flask will move down and the vacuum will be lost.
- 6.) Flask has cracks.
- 7.) Wrong choose in casting mould of program parameter (right is 'Flask').

7.13 Diagram casting flasks with flange

Figure 43: Flasks with flange

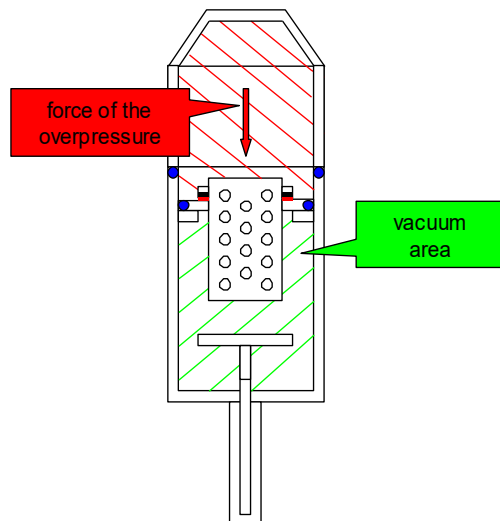

Possible reasons of losing vacuum.

- 1.) Flask flange is not flat enough.
- 2.) Silicon ring is missing or faulty.
- 3.) Flask has cracks.
- 4.) Wrong choose in casting mould of program parameter (right is 'Flask FI').

7.14 Service

If you need technical support from company INDUTHERM, we'd like to have the **following information** of your machine at first contact:

- Service No. M21999 F below mains switch or
- Serial number from identification plate at machine backside.
- Parameter printout. Please press button 'Printer' at front panel for 5 seconds incessantly.

8 Maintenance

8.1 Safety advices for repair and maintenance

For reliable use and highest work accuracy use a prerequisite is regular maintenance and service of your system. The necessary working steps are summarized in this chapter and have to be carried out in time.



Warning!

Perform maintenance and repair work on the system only if the system has been disconnected from the power supply (pull the plug).



Danger!

Danger of death from touching electrical parts.

Work on electrical equipment must only be performed by authorized personnel.

Access to the electrical installation room is allowed only for authorized personnel with a tool.

Work on the electrical equipment must only be carried out when the system has been disconnected from the power supply (pull the plug).

- The capacitors may still be charged even after turning off the system.
- The cabinet of the vacuum pressure casting machine must be kept close always.
- No work carried out on energized parts.
- Eliminate loose connections.
Replace damaged, scorched or burned cables immediately. Perform work only when the mains plug is out.
- Cables must not be clamped or pinched. Cables must be routed so that they do not form a tripping hazard or be damaged.



Danger!

Risk of health problems due to exposure to medium from damaged hoses. Risk of damage to the system.

- Eliminate loose connections. Replace damaged hoses immediately. Maintain only when the mains plug is out.
- Hoses must not be clamped or pinched. Hoses must be routed so that they do not form a tripping hazard or be damaged.

**Warning!**

Risk of injury.
Make pressurized plant parts at zero pressure before work is carried out there.

**Warning!**

Slipping on the floor in the area around the plant, if lubricants or solvents were spilled.
Clean the floor with dirt immediately! Discard the cleaning cloths in the collecting means made available.

**Caution!**

Health hazard due to inhalation of fibre particles.

- Wear dust protection mask.
- Store the crucible shield and insulation in a dustproof package.
- Remove the material immediately before installation.
- Don't shatter crucible shield and isolation.
- Pack the materials immediately dustproof after removal and dispose of these materials in this packaging.

8.2 Maintenance schedule

Follow the maintenance schedule to obtain the functionality of the system.

Daily (before casting)

Warning!

Burning hazard because of leaking molten metal.

The system must not be operated without a sealing rod for security reasons.



The tip of the sealing rod must stay in the pouring opening even when sealing rod is open.

When built-in and closed sealing rod the sealing rod-cylinder must not be on the lower end position, otherwise the sealing of the pouring hole is no longer guaranteed.

Check in case of an error necessarily the extent of sealing rod, graphite ball, crucible and the crucible bottom insulation.

- Remove thermocouple, crucible and insulating materials. Clean inductor housing carefully with a vacuum cleaner. Before installing check components and replace if necessary.
- Clean the metal filter on the left of the sealing rod.

Figure 44: Filter crucible chamber



With using of compressed air wear a dust proof mask and must not blow in the room.



- Check and replace white filter for vacuum if necessary.

Weekly

- Apply on the thread of the sealing rod high-temperature grease.
- Check oil level at vacuum pump. Renew oil if necessary. Recommended oil quality HD30/SAE30 (about 0.5 litres).

Every 4 months

- Check the vacuum filter and the oil separator filter of the vacuum pump. Check oil level. Check/clean air filter. Renew it.

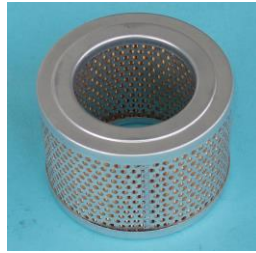
**Figure 45: air filter of vacuum pump****Every year**

- If you use tap water for cooling water-system, then pump about 25 % citric acid solution for about an hour through the system. Afterwards flush the system thoroughly with clean water and check for possible leaks. This cleaning-supply cycle is highly dependent on the hardness and cleanliness of the cooling water.
- Tighten all electrical connections, especially the high current connections.
- Retighten all screws of the water cooling, compressed air and protective gas supply.
- Renew oil separator filter of vacuum pump.

Figure 46: Oil separator filter of vacuum pump**Every 4 years**

- Repeat electrical test of the device.

The intervals of 4 years relate to a trouble-free operation of the electrical equipment. After an exchange of components (repair or extension) tests must be carried out. These tests are described in: EN60204-1: 2006 + A1: 2009.

**Note:**

The operator is in accordance with the Industrial Safety Regulation (BetrSichV) in Germany or pursuant to Directive 2009/104 / EC * in the EU required to define the cycle for the safety inspection of mechanical and electrical equipment.

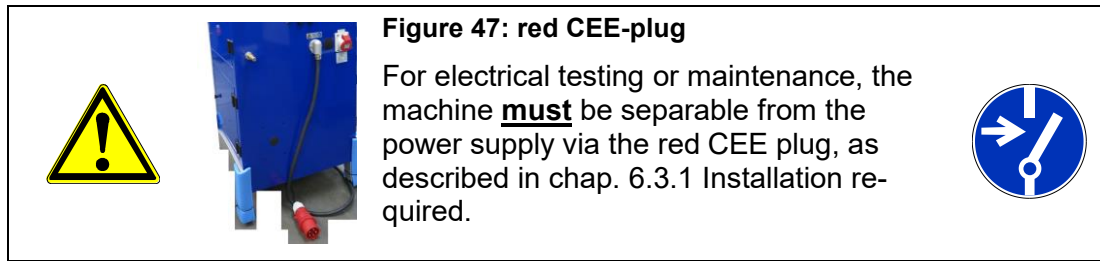

8.3 Repair

The system must be repaired only by authorized personnel. Never try to repair the system yourself. Incorrect repairs can lead to health problems or damage to the equipment.

*Directive 2009/104/EG

of the European Parliament and of the Council of 16 September 2009 concerning minimum safety and health protection for the use of work equipment by workers at work (second individual Directive within the meaning of Article 16 paragraph 1 of Directive 89/391 / EEC).

9 Dismantling and cleaning up



Warning!

Permanent skin damages after touching lubricant or solvent of every description (long term effects).

- Avoid touching lubricants, solvents and coolants.
- Wash the sprinkled skin parts thoroughly.
- Wear protective gauntlets when using lubricants, solvents and coolants.





Attention!

Disposal of possibly inserted lubricants and harmful cleaning agents are strictly regulated by the Environmental Protection Act and its regulations.

- Dispose of used lubricants at the hazardous waste collection point.
- Spilled lubricants: Immediately sprinkle with binder and dispose of after binding as hazardous.
- Meet catch precautionary, spilled feed materials (sealed bottom, catch basins, collecting tarpaulins).



- > Separate the system off the mains supply and other supply connections.
- > Depressurize all system parts which can be under pressure.
- > Dispose the system with the help of an appropriate lifting gear.
- > Clean the parts of the system.
- > Follow legal regulations at handling and cleaning up of old system parts.
- > Bring metal pieces to the recycling.

10 Annexe

10.1 List of figures

Figure 1: Sensor #84400010	1-1
Figure 2: overall view	4-2
Figure 3: backside of the vacuum pressure casting machine	4-3
Figure 4: Setup of the crucible chamber	4-4
Figure 5: Illustration of the self-rotating rubbing mechanism	4-4
Figure 6: refill system	4-5
Figure 7: adjustment of grain detector	4-5
Figure 8: additional gas tank	4-6
Figure 9: option – dual measurement	4-7
Figure 10: granulation tank	4-8
Figure 11: example of second cooling system	4-8
Figure 12: option vacuum sealed hinged window	4-9
Figure 13: Service at inductor 110 mm	4-9
Figure 14: standard 240 mm	4-10
Figure 15: Pin-option 71114321	4-10
Figure 16: possible height 260 mm	4-10
Figure 17: lifting the weight	5-1
Figure 18: RCD	6-2
Figure 19: Waterflow	6-3
Figure 20: constant pressure regulator	6-3
Figure 21: data management software menu	6-5
Figure 22: casting log	6-5
Figure 23: Hand centered	7-1
Figure 24: main screen	7-3
Figure 25: Program parameter page 1	7-4
Figure 26: Program parameter page2	7-6
Figure 27: pre-set casting programs	7-7
Figure 28: System parameter	7-8
Figure 29: Service-Info-Page 1	7-9
Figure 30: Service-Info-Page 2	7-9
Figure 31: Front panel below display	7-10
Figure 32: Example command "Set in flask"	7-12
Figure 33: sectional view of flask	7-15

Figure 34: flask without flange and holes	7-15
Figure 35: crucible without hole.....	7-16
Figure 36: Program parameter granulating page 1	7-17
Figure 37: Program parameter granulating page2.....	7-17
Figure 38: adapter for flask chamber	7-18
Figure 39: granulating insert	7-19
Figure 40: File for casting reports.....	7-19
Figure 41: Example print out	7-19
Figure 42: Flasks without flange.....	7-21
Figure 43: Flasks with flange.....	7-21
Figure 44: Filter crucible chamber	8-3
Figure 45: air filter of vacuum pump	8-4
Figure 46: Oil separator filter of vacuum pump.....	8-4
Figure 47: red CEE-plug	8-5
Figure 48: connection diagram – power part	10-6
Figure 49: connection diagram – control	10-7
Figure 50: connection diagram – temperature sensor, digital I/O ..	10-8
Figure 51: Assembly drawing with wall measurement	10-9
Figure 52: contact form Webshop	10-12
Figure 53: Webshop help with machine messages	10-12

10.2 CE-Declaration of conformity

Manufacturer:	INDUTHERM Erwärmungsanlagen GmbH Brettener Str. 32, 75045 Walzbachtal
Product type:	Vacuum-pressure-casting-machine
Machine type:	VC680V
Serial number:	18230 or higher
Authorized to sign:	Peter Hofmann

We herewith declare that the machine named above corresponds to the essential safety and health requirements of the following EC directives because of its design and construction in the version which we have placed on the market.

Legal normative basis

Directive 2006/42/EC on machinery in extracts

Reference Directive 2006/42 / EC, EU-Ab. No L 157/24 of 9 June 2006

EN 60204-1:2006+A1:2009

Security of machines
Electrical equipment of machines
Part 1 General requirements

EN 61010-1:2010 (in extracts)

Safety requirements for electrical equipment for measurement, control and laboratory use
Part 1: General requirements

EN ISO 12100:2010

Safety of machinery
General principles for design
Risk assessment and risk reduction

EN 349:1993+A1:2008

Safety of machinery
Minimum gaps to avoid crushing of parts of the human body

EN ISO 13849-1:2015

Safety of machinery
Safety-related parts of control systems
Part 1: General principles of design

EN ISO 13849-2:2012

Safety of machinery
Safety-related parts of control systems
Part 2: Validation

<p>EN ISO 13850:2006 Safety of machinery Emergency stop function – Principles of design</p>
<p>EN ISO 13857:2008 Safety of machinery Safety distances to prevent hazard zones being reached by upper and lower limbs</p>
<p>EN ISO 14120:2015 Safety of machinery Guards – General requirements for the design and construction of fixed and moveable guards</p>
<p>EN 1037:1995+A1:2008 Safety of machinery Prevention of unexpected start-up</p>
<p>EN ISO 11201:2010 Acoustics Noise emitted by machinery and equipment – Determination of emission sound pressure levels at a work station and at other specified positions in an essentially free field over a reflecting plane with negligible environmental corrections.</p>
<p>Directive 2014/30/EU on Electromagnetic Compatibility Reference Directive 2014/30 / EU, EU-Ab. No L 96/79, 29 March 2014</p>
<p>EN 61000-6-2:2005 Electromagnetic compatibility (EMC) Part 6-2: Generic standards - Immunity for industrial environments</p>
<p>EN 61000-6-4:2007+A1:2011 Electromagnetic compatibility (EMC) Part 6-4: Generic standards - Emission standard for industrial environments</p>

The declaration of conformity relates only to the machine in the state in which it was placed on the market; Parts and / or retrospective interventions carried out subsequently by the end user remain unaffected.

The test protocols are stored at INDUTHERM Erwärmungsanlagen GmbH for 10 years.



city/date/signatory:Walzbachtal/2021-10-12/Peter Hofmann, chairman

10.3 Test result chart

	1	2	3	4	5	6
Material						
Quantity						
Type of cast pieces						
Casting problem						
Crucible-temperature						
Casting mode (standard, vacuum, over-pressure)						
Flask-size (casting mould)						
Flask temperature						
Investment						
Particularities						
Result						
Test date						

Figure 49: connection diagram – control

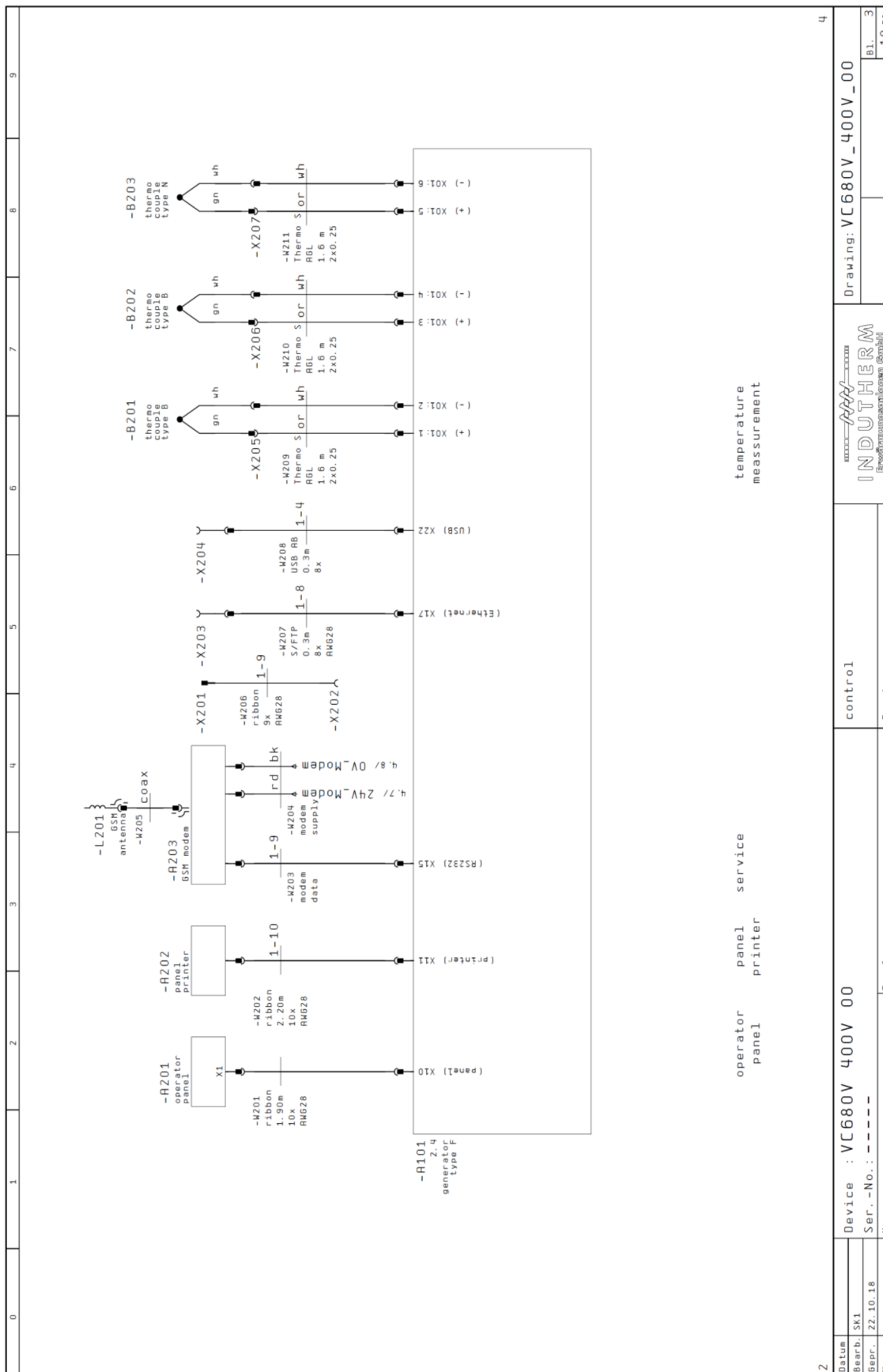

Datum	2
Bearb. SK1	
Gepr. 22.10.18	
Norm	

Device : VC680V 400V 00	control
Ser. -No. : - - - -	Ers. d.
Ursprf.	



Drawing: VC680V_400V_00	
Bl. 3	
1.0 Bl.	

Figure 50: connection diagram – temperature sensor, digital I/O

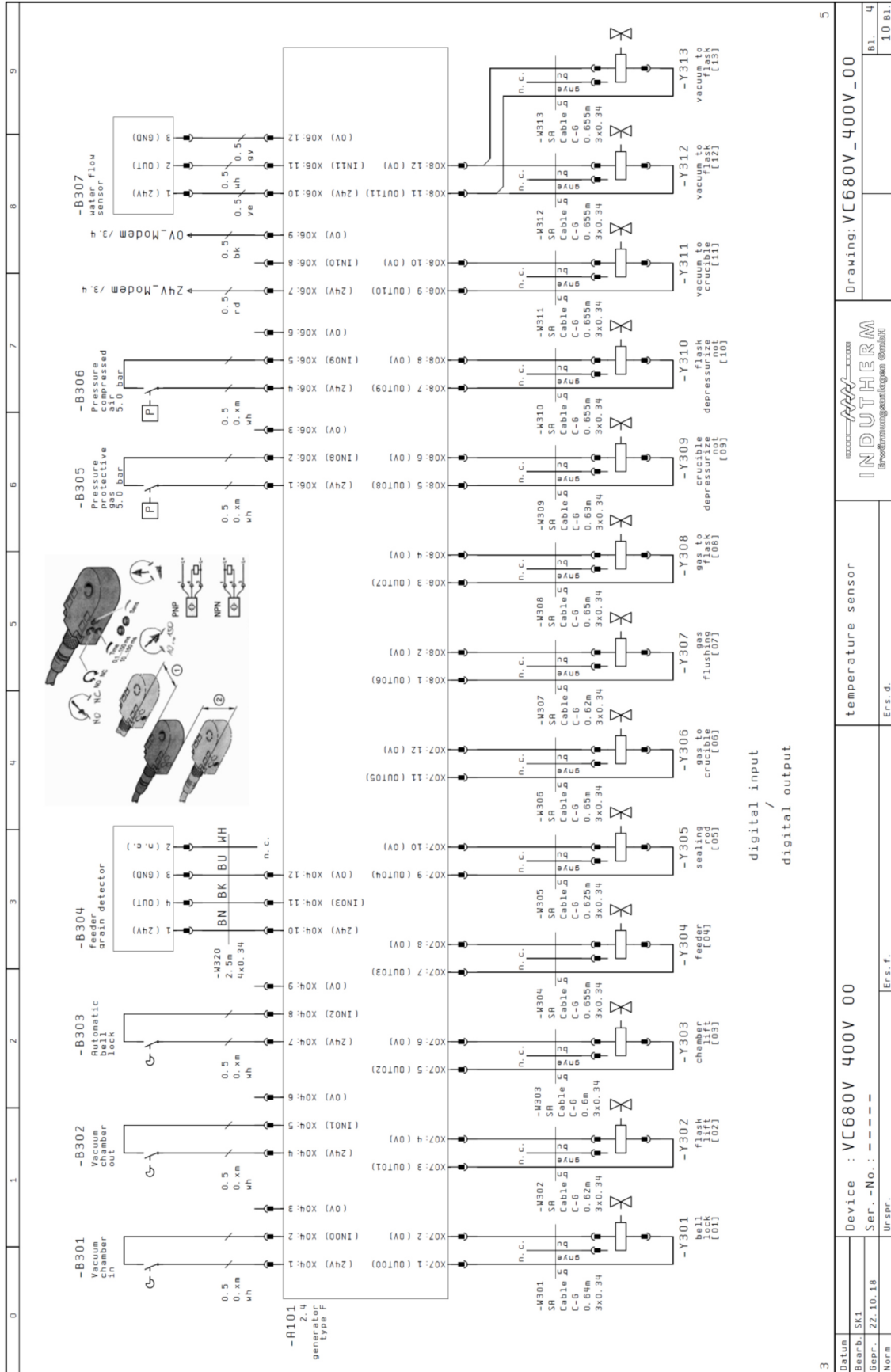

10.5 Assembly drawing VC680V

Figure 51: Assembly drawing with wall measurement

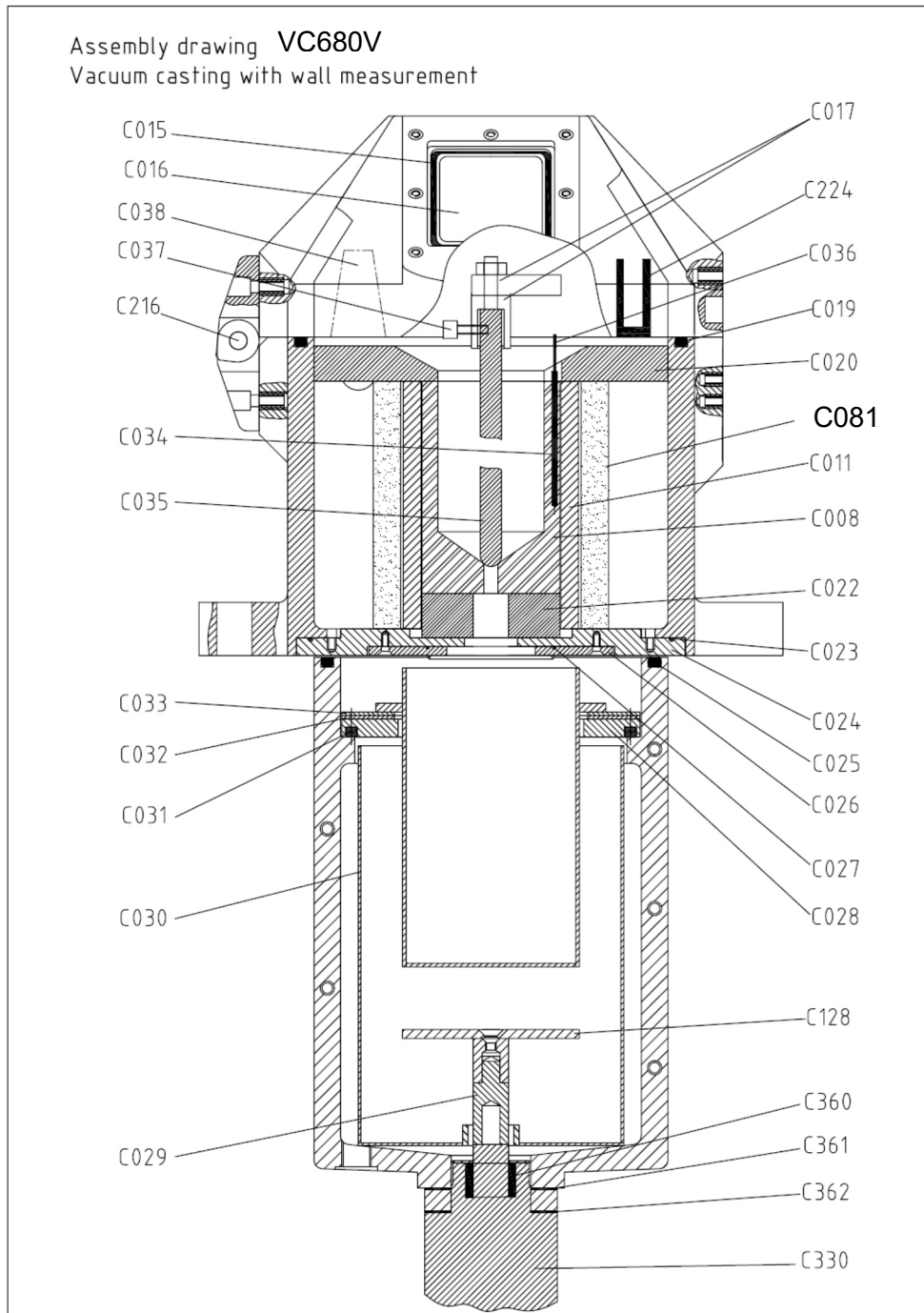

Attention:



The numbers like C008 are placeholder for the position in the machine. The article number to order this piece is 8 digits and listed in your machine specific order list G21999_00.pdf.

10.6 Consumable and spare parts list

INDUTHERM is now using only machine specific spare parts list, which contain all the information for your machine.

At following page, the spare parts list for this machine will start.

The item number of the consumables list is composed by following parts:

- G (for starter kit/basic equipment)
- The next five digits are the machine service number.
- The following combination of letters describe the application (please further below.
- The last two digits are the actual state, starting with ‘_00’.

One example: G21999_VC_00. This is the consumables list of machine no. 21999, equipped as vacuum pressure casting machine with delivery index ‘00’.

At request we can send you the actual consumables list in PDF-format. Is there a consumable part or replacement piece replaced by an advanced or better one, changes the index number in the end of item no. in ascending order, in this case to G21999_VC_01? This list replaces the previous edition with index ‘_00’. This should lead to the situation you have always access at the actual consumable and replacement parts of your machine.

Is your machine equipped with options like sinter or granulating, there are for this options specific consumables and spare parts list:

G21999_VC_00	Every part for vacuum casting.
G21999_SI_00	Every part for sintering.
G21999_GR_00	Every part for granulating.
G21999_PA_00	Every part for steel and palladium casting.

For ordering of replacement and consumable parts please contact Romanoff at 631-842-2400 or email service@romanoff.com